

4-Pole

50/60 Hz



BOTTOM INTAKE SUBMERSIBL MOTOR **RX10-BI**

Wet Wounded Stator Motor
For Vertical and Inclined Installation

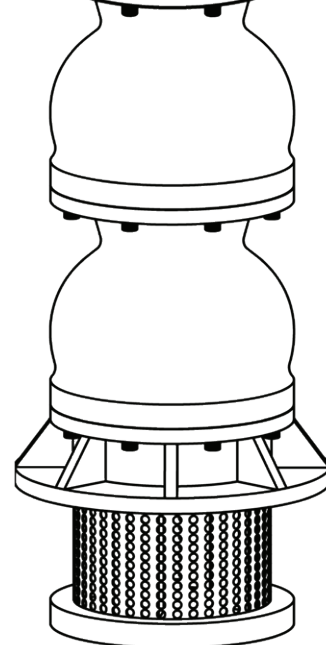



// Introducing the RX10-BI Bottom Intake Submersible motor – a revolution in cost-effective pumping solutions. Unlike surface centrifugal pumps, the RX10-BI eliminates the need for pump-house construction and suction lines, reducing infrastructure costs. With direct tank installation, it not only maximizes efficiency but also minimizes leftover in the tank, outperforming ordinary submersible motors and pumps. Ideal for river water pumping, mining applications, and more, the RX10-BI ensures a lean, efficient, and practical approach to your water pumping needs! **//**



**BOTTOM INTAKE MOTORS
10-INCH, 4-POLE, 50/60 Hz**



RX10-BI

**Wet Wounded Stator Motor
For Vertical and Inclined
Installation Applications**

Power Range

From: 40 HP (30 kW)

To: 175 HP (130 kW)

Voltage Range

460 Volts @ 60 Hertz

415 Volts @ 50 Hertz

Speed Range

4 Poles - 1800 RPM @ 60 Hertz

4 Poles - 1500 RPM @ 50 Hertz

Construction Material

Standard: Cast Iron with NSF Certified Epoxy

Optional: Complete 316L Stainless Steel

Specification Overview

Mounting Position	Vertical/Horizontal
Degree of Protection	IP68
Insulation Class	Y*
Working Temperature	122° F
Voltage Tolerance	+6% to -10%
Req: Cooling Flow Speed	0.5 ~ 12 ft/sec
Max. Immersion Depth	650 Feet
Max. Starts per Hour	10 Nrs

* Higher insulation class wire available

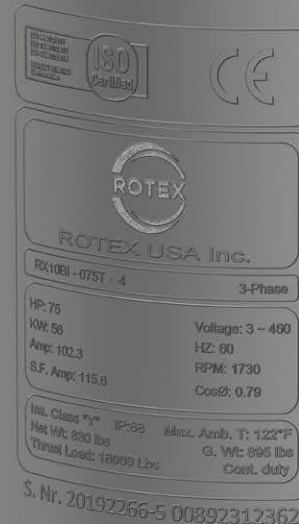

Introduction

The innovative design of the bottom intake submersible motor seamlessly merges the technical advantages of a submersible motor with those of a turbine shaft pump. In traditional submersible pump systems, the intake point is located in the middle or above the midpoint of the pump's length, requiring a substantial amount of fluid in the source reservoir to fully submerge the pump intake, and causing excessive leftover. Consequently, these conventional submersible pump setups exhibit limitations when used for pumping in mining and dewatering operations, as well as for extracting water from ponds, open channels, rivers, and surface reservoirs in agricultural and various other applications.

The bottom intake submersible pump system repositions the intake point to the bottom of the pump, thereby requiring only a minimal fluid level in the reservoir. This innovation enhances the versatility of its applications by eliminating the need for substantial fluid levels, making it a more flexible choice for various scenarios.

Construction & Working

The bottom intake submersible motor boasts a comprehensive design featuring an outer shroud that envelops the entire motor assembly. Positioned at the bottom end is a pump coupling adapter, where your pump is coupled just like a turbine pump. At the top, a discharge manifold-head system is in place. The pump, along with a required suction strainer at its base, should include an integrated anti-vortex plate, followed by a single or multistage pump. Within the pump coupling adapter, intricately connected to the lower end of the motor, the pump shaft couples with the motor shaft. The fluid being pumped flows over the motor stator tube, enclosed by an external shroud, and is directed through manifolds to the discharge component, converging seamlessly before entering the discharge pipes.

An exceptional feature of the discharge manifolds lies in their ability to segregate the sealing system for power cables from the high-pressure discharge line. This design ensures the integrity of these critical elements even in demanding operational conditions.

Advantages

- The motor shaft sealing system and the thrust bearing lies in the bottom of the motor, hence more effectively lubricated and cooled.
- The pumped fluid passes over the stator, hence more effective cooling with forced convection.
- The intake of the pump-set is at the bottom, hence allowing greater application flexibility.

Specifications

Winding: The winding comprises Electrolytic Solid Copper wire wrapped in BOPET+BOPP Insulation, designed to withstand temperatures exceeding 212°F. This innovative configuration enables lower fill factor of the stator slots. As a result, this technology facilitates superior heat dissipation by allowing better coolant contact, enabling the motor to operate at lower temperatures and attain horsepower ratings beyond the usual standards for standard frame sizes.

Stator: Rotex bottom intake motors have an extended stator stack length, with stator lamination made of low-loss electrical magnetic sheet, resulting in reduced heat generation within the stator, thus ensuring cooler operational temperatures.

Rotor: Characterized by an augmented stack length, the rotor is lamination is precisely engineered and made of low-loss electrical magnetic sheet. This design is further complemented by the utilization of high-grade copper bars, ensuring optimal performance. The rotor is dynamically balanced using the latest technology.

Motor Shaft: The over-sized design of the shaft, use of superior quality stainless steel AISI 431, and special post machining process including induction hardening and precise grinding guarantee dependable performance, even in the most demanding environments. Its dimensions are designed to meet the specifications for all keyway shaft types, emphasizing its exceptional compatibility and top-notch quality.

Radial Bearing / Bush: Enhancing operational efficiency in sandy well environments and facilitating effective pump vibration control, the upper and lower brackets host pairs of dual water-lubricated carbon bushes. Constructed from high-grade carbon, these bearings ensure robust performance and durability.

Thrust Bearings: Rotex bottom intake motor employs an exclusively engineered and manufactured Tilting Pad Thrust Bearing. Developed and manufactured entirely in-house, these bearings undergo rigorous testing in Rotex's dedicated thrust bearing testing facility. Lubricated by water, they effectively counter the thrust load generated by the pump, ensuring optimal performance and longevity. Available with an axial load capacity up to 18000 Lbs.

Sealing System: Rotex bottom intake motors feature a robust 3-layer sealing system, incorporating two outer lip seals arranged in a back-to-back configuration, complemented by an internal mechanical seal made of silicon/tungsten carbide. This strategic combination provides an unparalleled level of protection, especially in sandy well environments.

Pressure Equalizing System: The bottom intake motors employ a precisely dimensioned and shaped pressure balancing system to adeptly manage pressure fluctuations. This specialized system transmits the discharge line pressure to motor internal fluid without a direct contact between the two, and thus guarding the mechanical seal from the excessive pressure of the discharge line.

Filler Fluid: Rotex bottom intake motors are filled with a blend of water and non-toxic antifreeze to deliver both cooling and lubrication benefits. Additionally, this mixture serves to safeguard internal components against corrosion and deterioration.

Cable and Connection: Using premium-grade PVC/XLPE sheathed copper cable for connections. Offered in both Delta and WYE (Star) configurations.

Applications

- Agriculture (Irrigation and Drainage)
- Industrial (Customized inline installation)
- Water Treatment and Distribution
- Flood Drainage and Dry docks
- Ballast & De-Ballast Systems
- Mining Industry
- River or Lake Water Lift
- Emergency Drain Pumps
- Storage Reservoirs
- De-Watering

Installation Positions

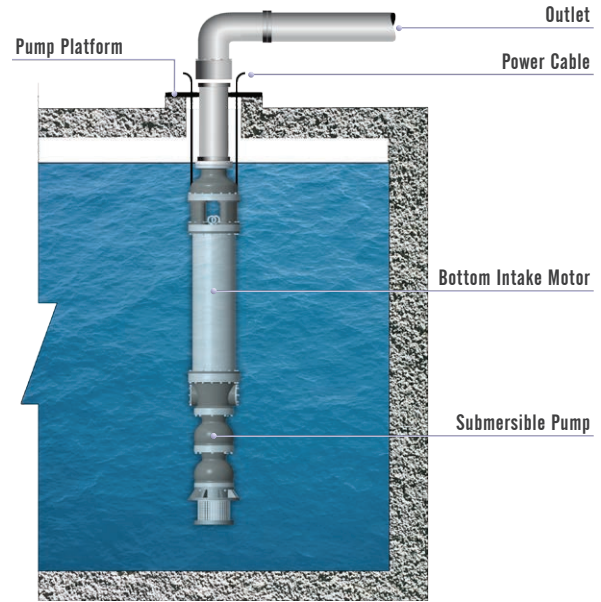

Water Tank Installation

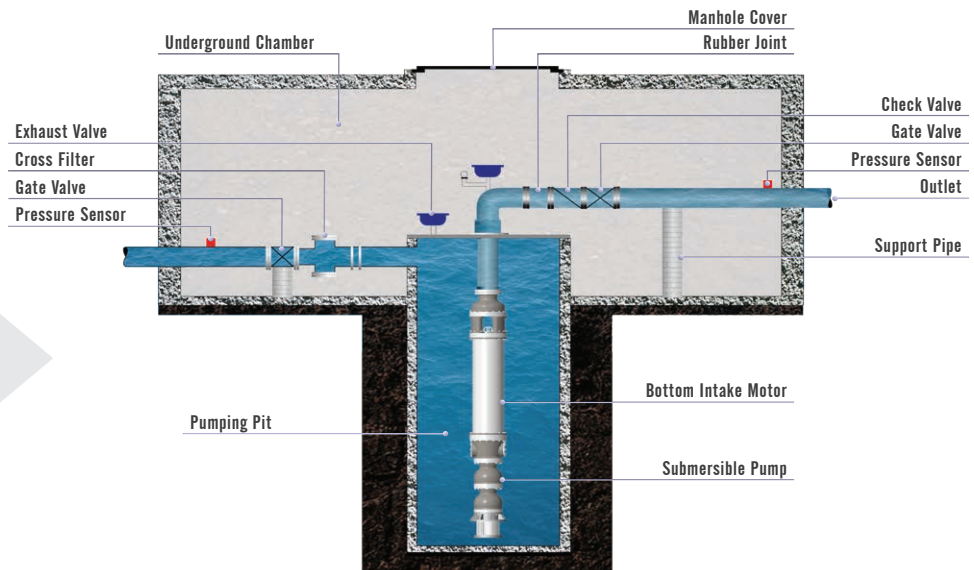

Underground Installation

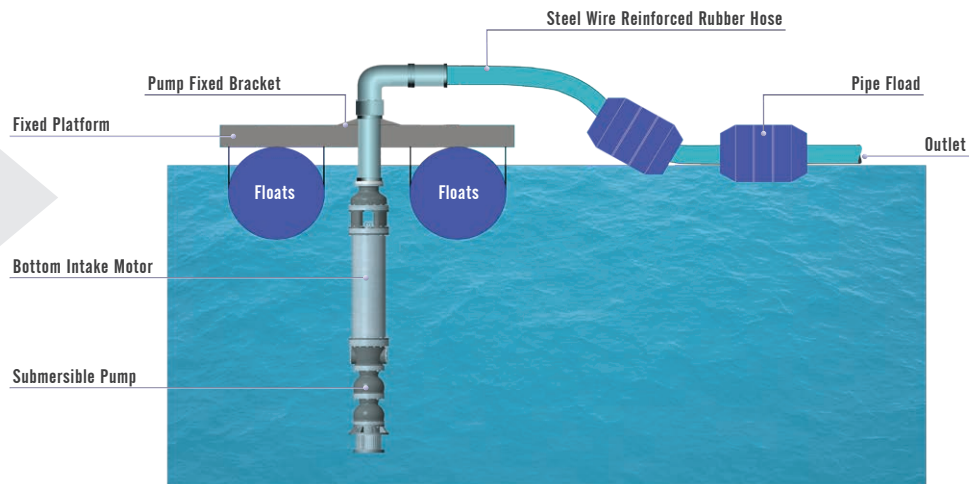

Surface Installation

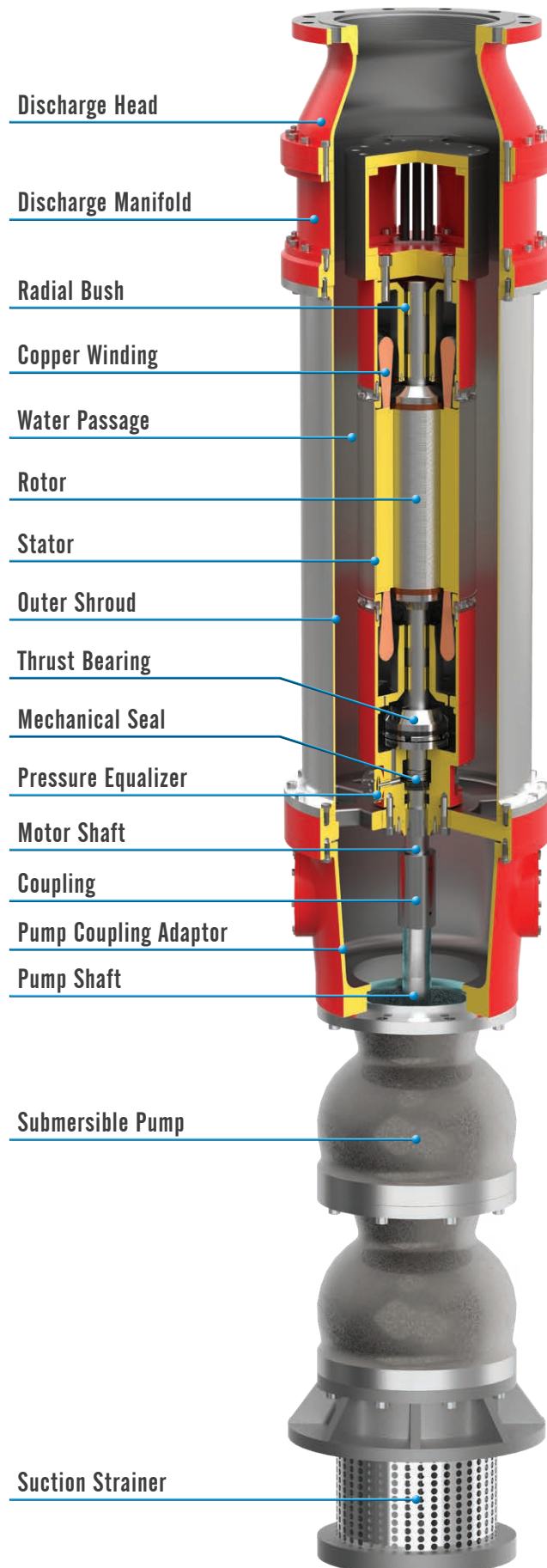

Technical Data - 4 Pole - Three Phase - 460V - 60 Hz

Motor Type	Motor Size		Thrust Load (Lbs)	RPM	Full Load Current (Amp.)	SF Load Current (Amp.)	Starting Current (Amp.)	Cos. ϕ at Full Load	Efficiency at Full Load (%)	Service Factor
	HP	KW								
RX10BI-040-4	40	30	18000	1715	54.2	60.7	285	0.80	86.0	1.15
RX10BI-050-4	50	37	18000	1720	68.5	76.9	385	0.79	86.5	1.15
RX10BI-060-4	60	45	18000	1725	81.2	91.6	495	0.80	86.9	1.15
RX10BI-075-4	75	56	18000	1730	102.3	115.6	624	0.79	87.0	1.15
RX10BI-100-4	100	75	18000	1725	134.2	153.8	846	0.80	87.1	1.15
RX10BI-125-4	125	93	18000	1730	167.7	192.4	1058	0.80	87.4	1.15
RX10BI-150-4	150	112	18000	1720	198.6	226.5	1291	0.81	87.3	1.15
RX10BI-175-4	175	130	18000	1715	229.0	261.7	1439	0.82	87.6	1.15

Technical Data Data - 4 Pole - Three Phase - 415V - 50 Hz

Motor Type	Motor Size		Thrust Load (Lbs)	RPM	Full Load Current (Amp.)	SF Load Current (Amp.)	Starting Current (Amp.)	Cos. ϕ at Full Load	Efficiency at Full Load (%)	Service Factor
	HP	KW								
RX10BI-040-4	40	30	18000	1420	61.1		287	0.80	85.1	1
RX10BI-050-4	50	37	18000	1420	75.2		376	0.81	85.1	1
RX10BI-060-4	60	45	18000	1425	89.9		485	0.81	85.5	1
RX10BI-075-4	75	56	18000	1425	111.7		603	0.81	85.6	1
RX10BI-100-4	100	75	18000	1420	151.0		831	0.80	85.6	1
RX10BI-125-4	125	93	18000	1425	185.9		1023	0.82	85.4	1
RX10BI-150-4	150	112	18000	1420	222.1		1266	0.82	85.9	1
RX10BI-175-4	175	130	18000	1415	257.2		1415	0.82	86.0	1

Size & Dimensions Motor Leads

4 Pole, Three Phase, 460 Volt - 60 Hz / 415 Volt - 50 Hz

Connection Type	Motor Size		Lead Size Nos. x Cross Section (mm ²)	Diameter D (inch)	Cable Length (Feet)	Qty (Nr.)
	HP	KW				
DOL	40 - 75	30 - 56	1 x 16	0.41	16	3
	100	75	1 x 25	0.46	16	3
	125 - 150	93 - 112	1 x 35	0.50	16	3
	175	130	1 x 70	0.68	16	3
SD	40 - 175	30 - 130	1 x 16	0.41	16	6

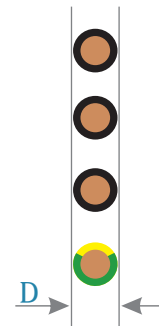

Additional core 1 x 10 mm² 16 feet for earthing.

Motor Performance Curves

Load	0%	25%	50%	75%	100%	115%	130%	Model	RX10BI-040-4
P2 (HP)	0.0	10.0	20.0	30.0	40.0	46.0	52.0	Motor Size (HP)	40
P2 (kW)	0.0	7.5	14.9	22.4	29.8	34.3	38.8	Motor Size (kW)	30
P1 (kW)	1.8	9.5	17.4	25.9	34.7	40.1	45.8	Voltage (V)	460
Current (Amp)	25.2	29.9	35.8	43.8	54.2	60.7	67.8	Frequency (Hz)	60
Efficiency (%)	0.0	78.9	85.6	86.5	86.0	85.5	84.7	Poles (Nos)	4
Cos phi (p.u)	0.091	0.397	0.612	0.741	0.804	0.830	0.848		
Speed (RPM)	1799	1780	1760	1737	1715	1701	1683		
Torque (Nm)	0.0	40.0	81.0	123.0	166.1	192.7	220.1		

Tolerances according to IEC 60034-1, Table-20.

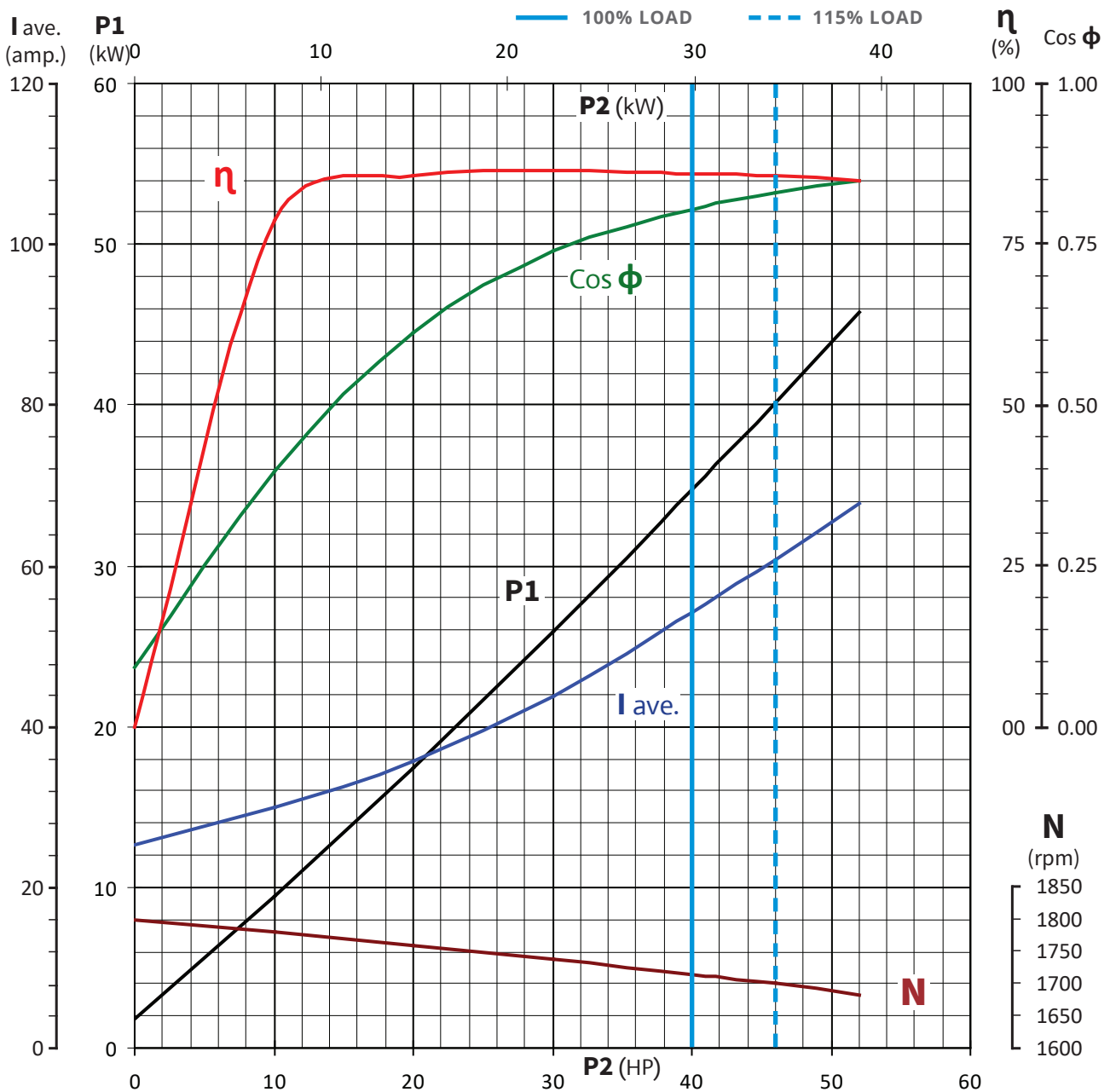



BOTTOM INTAKE MOTORS 10-INCH, 4-POLE, 50/60 Hz



Motor Performance Curves

Load	0%	25%	50%	75%	100%	115%	130%	Model	RX10BI-050-4
P2 (HP)	0.0	12.5	25.0	37.5	50.0	57.5	65.0	Motor Size (HP)	50
P2 (kW)	0.0	9.3	18.7	28.0	37.3	42.9	48.5	Motor Size (kW)	37
P1 (kW)	2.3	11.9	21.7	32.3	43.1	50.0	57.2	Voltage (V)	460
Current (Amp)	34.9	40.0	46.0	56.2	68.5	76.9	86.2	Frequency (Hz)	60
Efficiency (%)	0.0	78.4	85.9	86.7	86.5	85.9	84.8	Poles (Nos)	4
Cos phi (p.u)	0.081	0.373	0.592	0.720	0.791	0.815	0.833		
Speed (RPM)	1799	1781	1762	1741	1720	1707	1690		
Torque (Nm)	0.0	50.0	101.1	153.4	207.1	240.0	274.0		

Tolerances according to IEC 60034-1, Table-20.

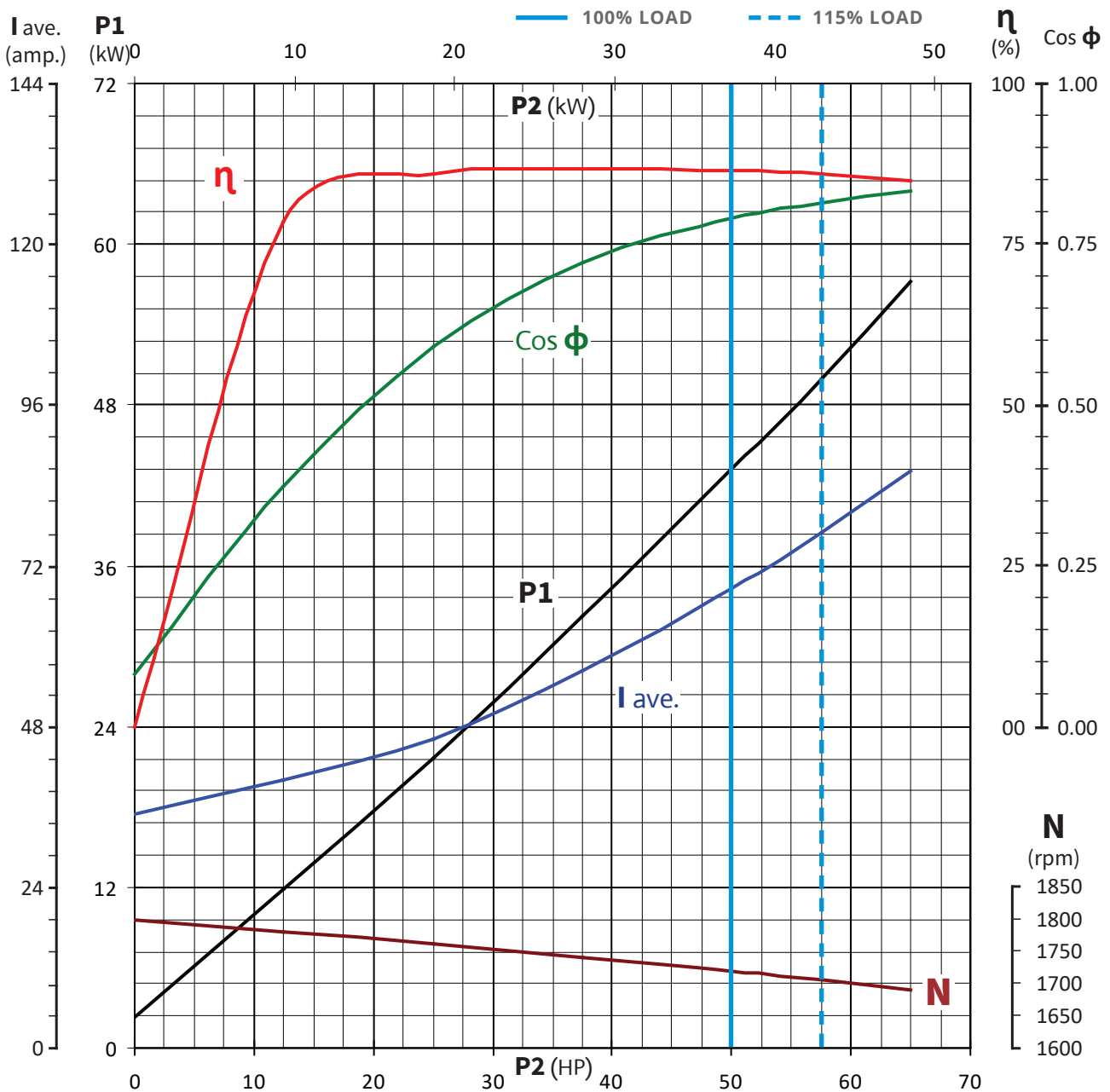

Motor Performance Curves

Load	0%	25%	50%	75%	100%	115%	130%	Model	RX10BI-060-4
P2 (HP)	0.0	15.0	30.0	45.0	60.0	69.0	78.0	Motor Size (HP)	60
P2 (kW)	0.0	11.2	22.4	33.6	44.8	51.5	58.2	Motor Size (kW)	45
P1 (kW)	2.6	14.1	25.9	38.5	51.5	59.8	68.7	Voltage (V)	460
Current (Amp)	39.5	46.3	54.1	66.5	81.2	91.6	102.9	Frequency (Hz)	60
Efficiency (%)	0.0	79.1	86.3	87.1	86.9	86.0	84.7	Poles (Nos)	4
Cos phi (p.u)	0.081	0.383	0.601	0.727	0.796	0.820	0.838		
Speed (RPM)	1799	1782	1765	1745	1725	1713	1697		
Torque (Nm)	0.0	60.0	121.1	183.7	247.7	287.0	327.5		

Tolerances according to IEC 60034-1, Table-20.

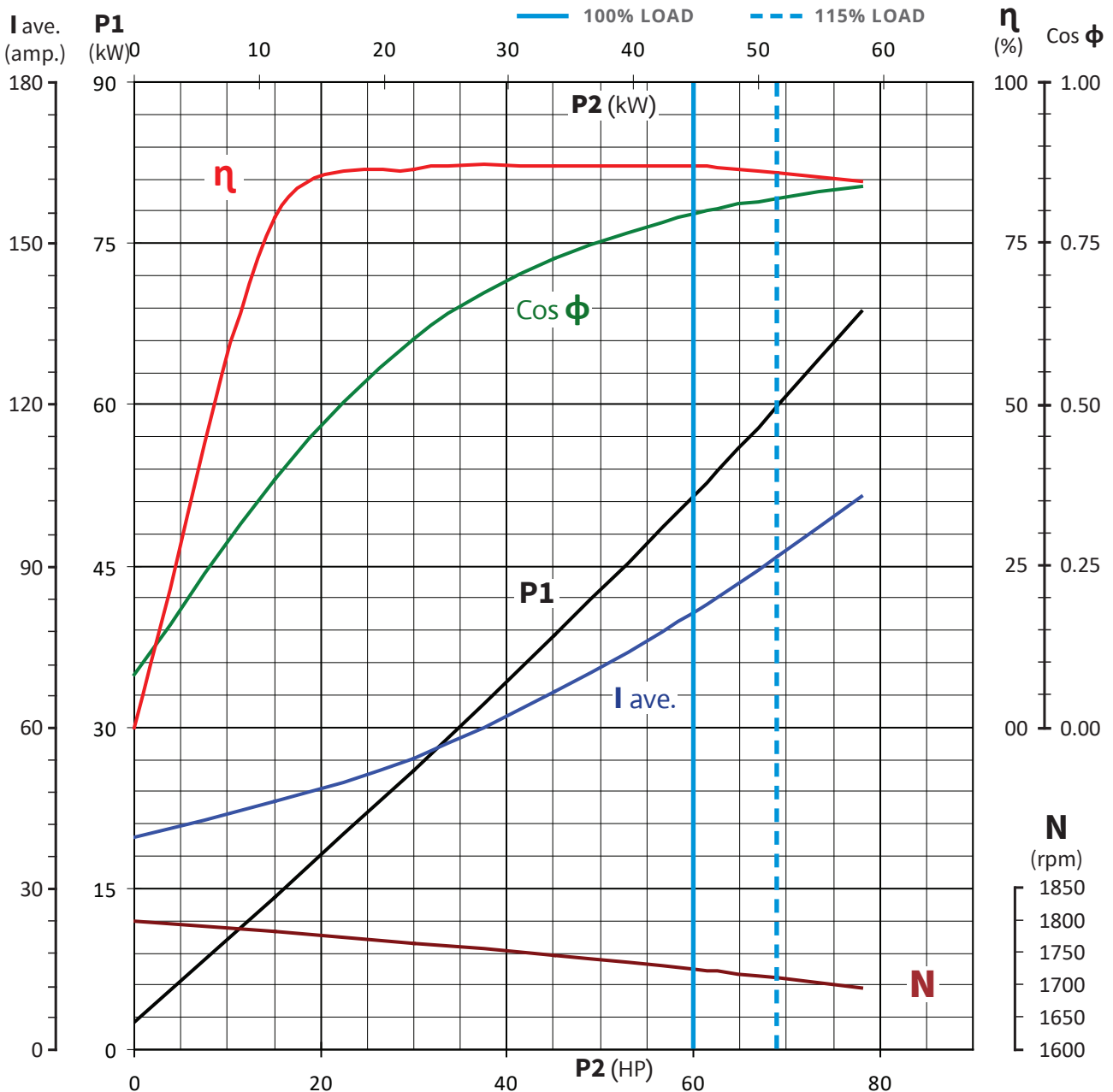



BOTTOM INTAKE MOTORS 10-INCH, 4-POLE, 50/60 Hz



Motor Performance Curves

Load	0%	25%	50%	75%	100%	115%	130%	Model	RX10BI-075-4
P2 (HP)	0.0	18.8	37.5	56.3	75.0	86.3	97.5	Motor Size (HP)	75
P2 (kW)	0.0	14.0	28.0	42.0	56.0	64.3	72.7	Motor Size (kW)	56
P1 (kW)	2.9	17.8	32.4	47.9	64.3	74.8	86.1	Voltage (V)	460
Current (Amp)	49.7	58.8	68.9	83.8	102.3	115.6	130.9	Frequency (Hz)	60
Efficiency (%)	0.0	78.8	86.3	87.7	87.0	86.0	84.5	Poles (Nos)	4
Cos phi (p.u)	0.074	0.379	0.591	0.717	0.789	0.812	0.826		
Speed (RPM)	1799	1783	1767	1748	1730	1718	1703		
Torque (Nm)	0.0	74.9	151.2	229.3	308.9	357.7	407.8		

Tolerances according to IEC 60034-1, Table-20.

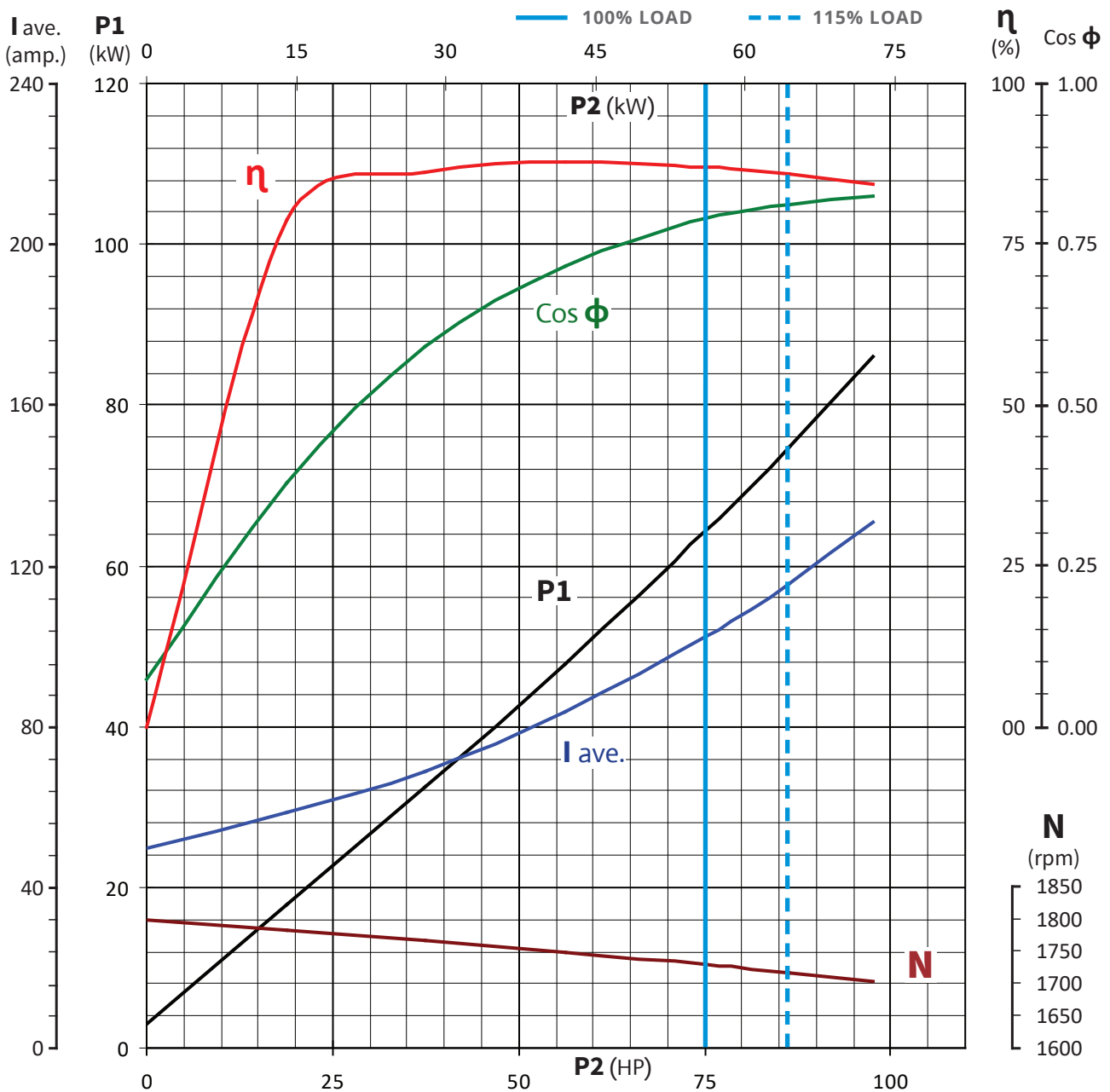

Motor Performance Curves

Load	0%	25%	50%	75%	100%	115%	130%	Model	RX10BI-100-4
P2 (HP)	0.0	25.0	50.0	75.0	100.0	115.0	130.0	Motor Size (HP)	100
P2 (kW)	0.0	18.7	37.3	56.0	74.6	85.8	97.0	Motor Size (kW)	75
P1 (kW)	3.2	22.3	42.2	63.4	85.6	100.4	116.7	Voltage (V)	460
Current (Amp)	57.4	66.5	83.9	107.2	134.2	153.8	176.3	Frequency (Hz)	60
Efficiency (%)	0.0	83.6	88.5	88.3	87.1	85.5	83.1	Poles (Nos)	4
Cos phi (p.u)	0.070	0.421	0.631	0.742	0.801	0.819	0.831		
Speed (RPM)	1798	1782	1764	1744	1725	1703	1680		
Torque (Nm)	0.0	100.0	201.9	306.3	413.1	481.1	551.4		

Tolerances according to IEC 60034-1, Table-20.

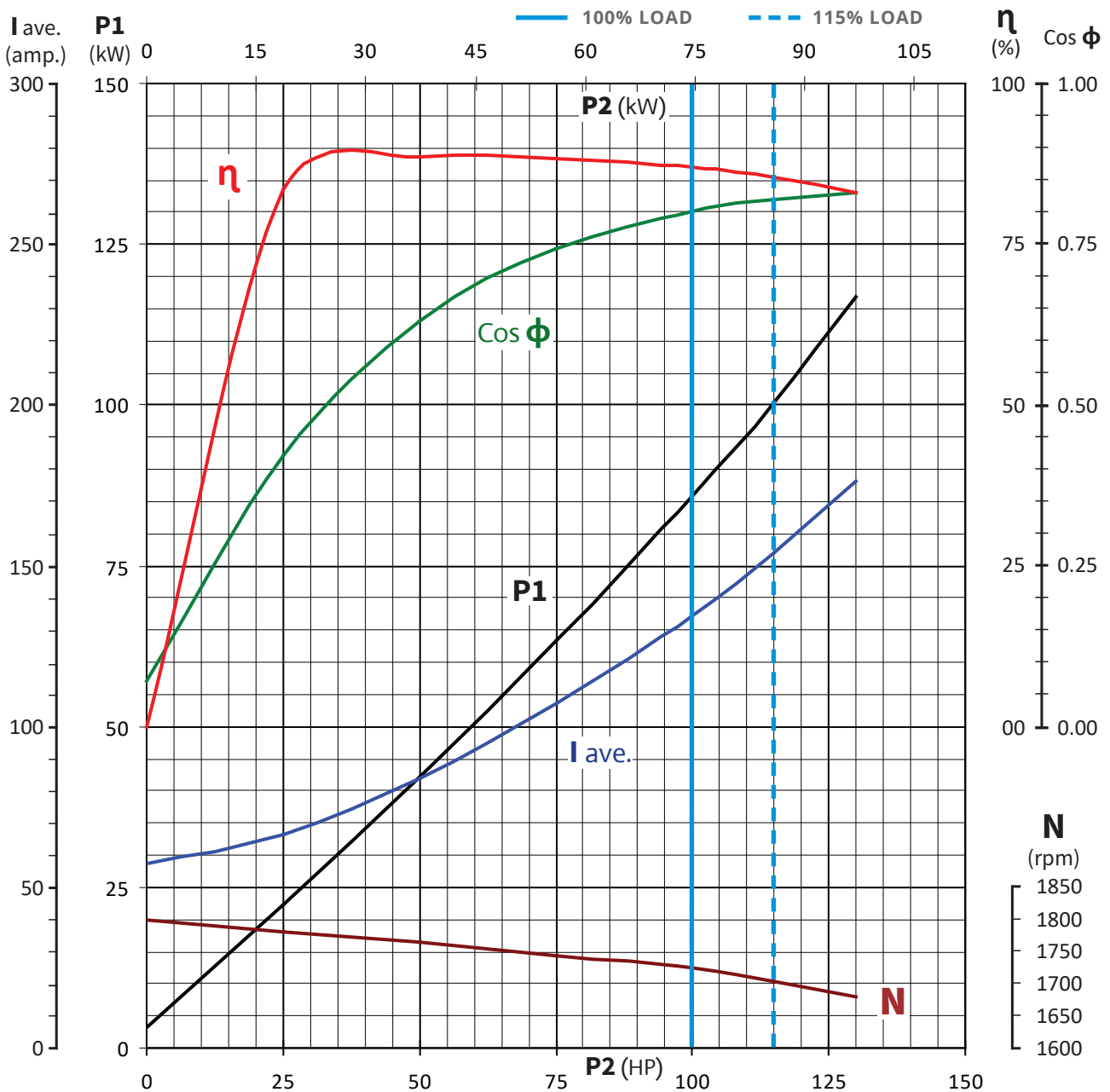



BOTTOM INTAKE MOTORS 10-INCH, 4-POLE, 50/60 Hz



Motor Performance Curves

Load	0%	25%	50%	75%	100%	115%	130%	Model	RX10BI-125-4
P2 (HP)	0.0	31.3	62.5	93.8	125.0	143.8	162.5	Motor Size (HP)	125
P2 (kW)	0.0	23.3	46.6	69.9	93.3	107.2	121.2	Motor Size (kW)	93
P1 (kW)	3.9	28.7	53.8	79.2	106.7	125.3	145.8	Voltage (V)	460
Current (Amp)	72.4	86.0	107.3	134.3	167.7	192.4	221.0	Frequency (Hz)	60
Efficiency (%)	0.0	81.2	86.7	88.3	87.4	85.6	83.2	Poles (Nos)	4
Cos phi (p.u)	0.068	0.419	0.629	0.740	0.798	0.817	0.828		
Speed (RPM)	1799	1782	1766	1748	1730	1709	1687		
Torque (Nm)	0.0	124.9	252.1	382.1	514.8	599.1	686.3		

Tolerances according to IEC 60034-1, Table-20.

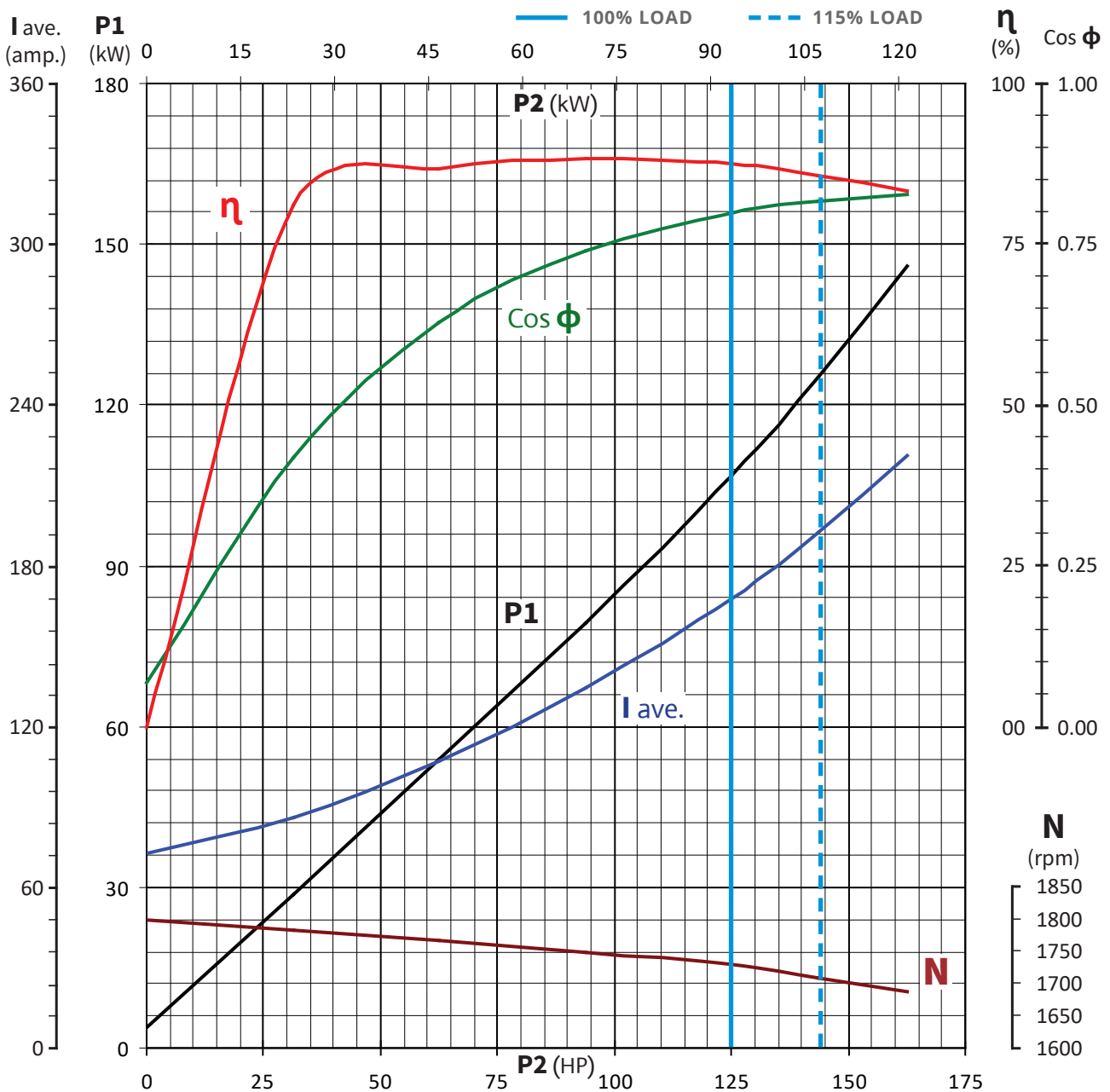

Motor Performance Curves

Load	0%	25%	50%	75%	100%	115%	130%	Model	RX10BI-150-4
P2 (HP)	0.0	37.5	75.0	112.5	150.0	172.5	195.0	Motor Size (HP)	150
P2 (kW)	0.0	28.0	56.0	83.9	111.9	128.7	145.5	Motor Size (kW)	112
P1 (kW)	5.3	34.7	64.8	95.1	128.2	150.1	174.7	Voltage (V)	460
Current (Amp)	82.4	104.1	127.4	158.6	198.6	226.5	259.2	Frequency (Hz)	60
Efficiency (%)	0.0	80.7	86.4	88.2	87.3	85.7	83.3	Poles (Nos)	4
Cos phi (p.u)	0.081	0.418	0.638	0.753	0.810	0.832	0.846		
Speed (RPM)	1799	1780	1762	1741	1720	1698	1672		
Torque (Nm)	0.0	150.1	303.3	460.3	621.2	723.8	831.1		

Tolerances according to IEC 60034-1, Table-20.

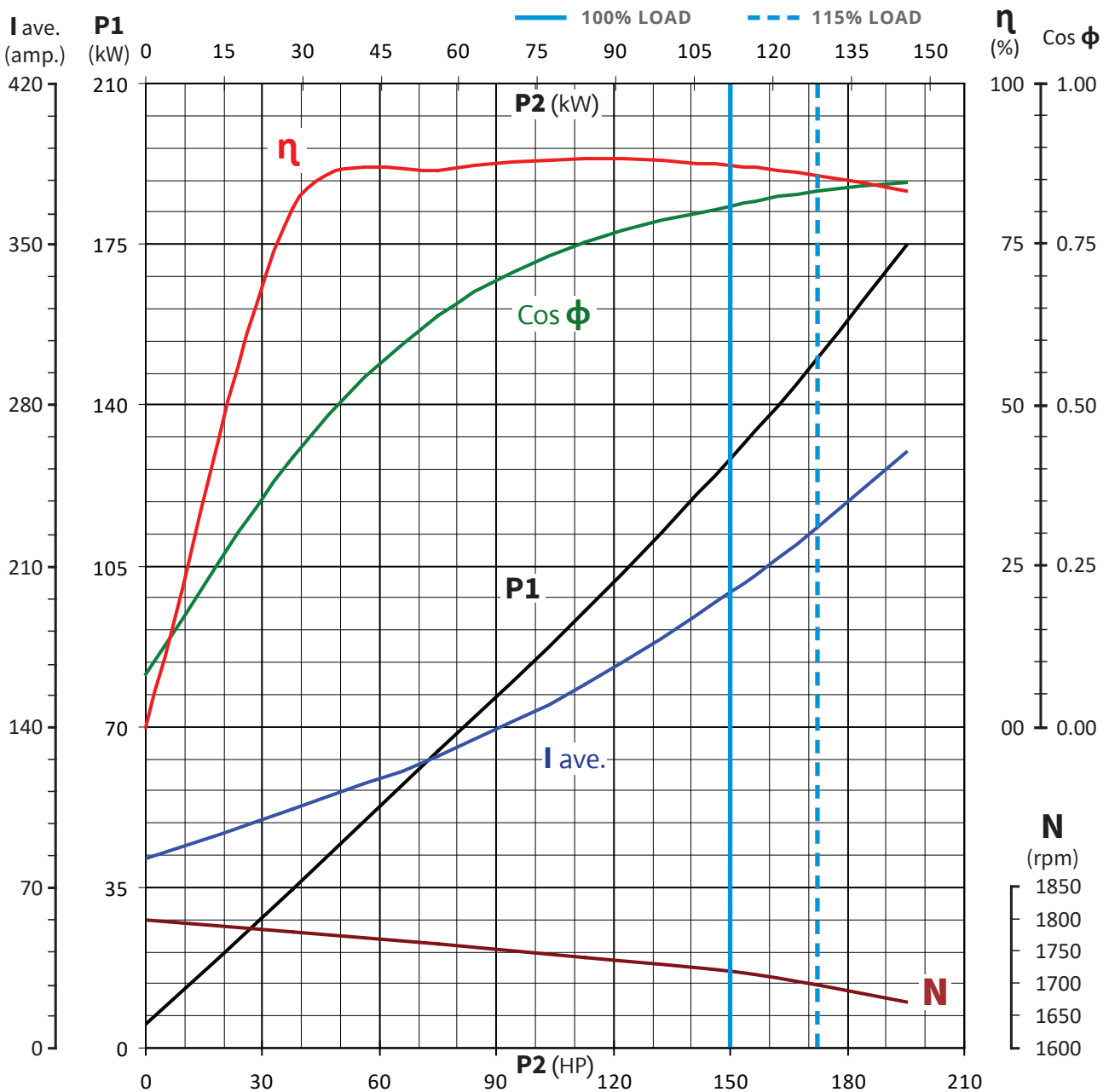



BOTTOM INTAKE MOTORS 10-INCH, 4-POLE, 50/60 Hz



Motor Performance Curves

Load	0%	25%	50%	75%	100%	115%	130%	Model	RX10BI-175-4
P2 (HP)	0.0	43.8	87.5	131.3	175.0	201.3	227.5	Motor Size (HP)	175
P2 (kW)	0.0	32.6	65.3	97.9	130.6	150.1	169.7	Motor Size (kW)	130
P1 (kW)	6.3	40.7	75.6	110.7	149.1	175.0	203.0	Voltage (V)	460
Current (Amp)	92.2	119.1	146.7	182.5	229.0	261.7	299.4	Frequency (Hz)	60
Efficiency (%)	0.0	80.2	86.3	88.5	87.6	85.8	83.6	Poles (Nos)	4
Cos phi (p.u)	0.086	0.429	0.647	0.761	0.817	0.839	0.851		
Speed (RPM)	1799	1779	1760	1737	1715	1691	1664		
Torque (Nm)	0.0	175.2	354.2	538.2	726.7	847.9	974.1		

Tolerances according to IEC 60034-1, Table-20.

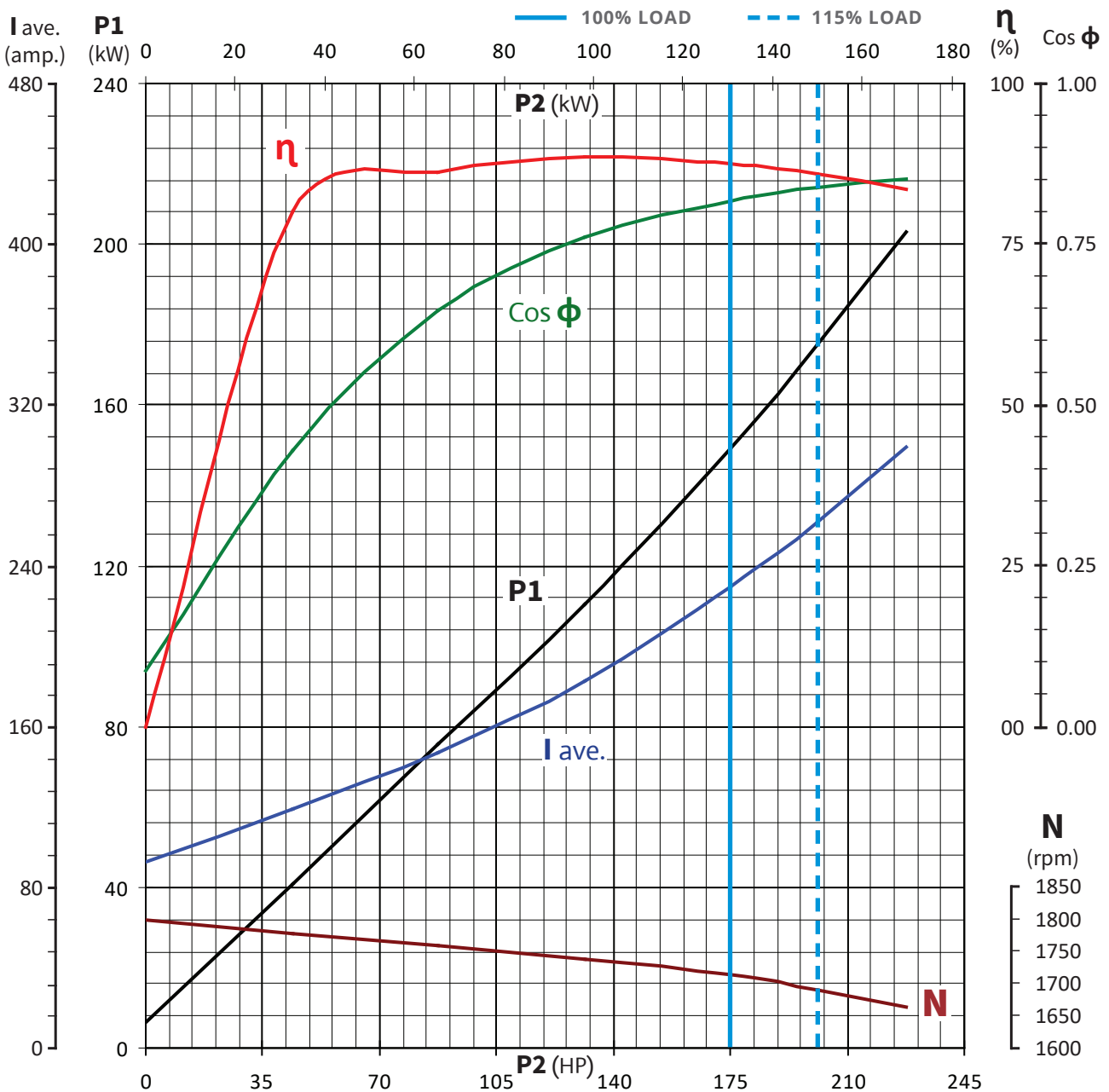

Motor Performance Curves

Load	0%	25%	50%	75%	100%	115%	130%	Model	RX10BI-040-4
P2 (HP)	0.0	10.0	20.0	30.0	40.0	46.0	52.0	Motor Size (HP)	40
P2 (kW)	0.0	7.5	14.9	22.4	29.8	34.3	38.8	Motor Size (kW)	30
P1 (kW)	1.9	9.6	17.6	26.2	35.1	40.7	46.4	Voltage (V)	415
Current (Amp)	32.6	36.5	42.3	50.7	61.1	68.7	77.1	Frequency (Hz)	50
Efficiency (%)	0.0	77.5	84.7	85.5	85.1	84.4	83.7	Poles (Nos)	4
Cos phi (p.u)	0.081	0.367	0.580	0.718	0.798	0.823	0.837		
Speed (RPM)	1500	1483	1464	1444	1420	1403	1380		
Torque (Nm)	0.0	48.1	97.3	148.0	200.6	233.6	268.4		

Tolerances according to IEC 60034-1, Table-20.

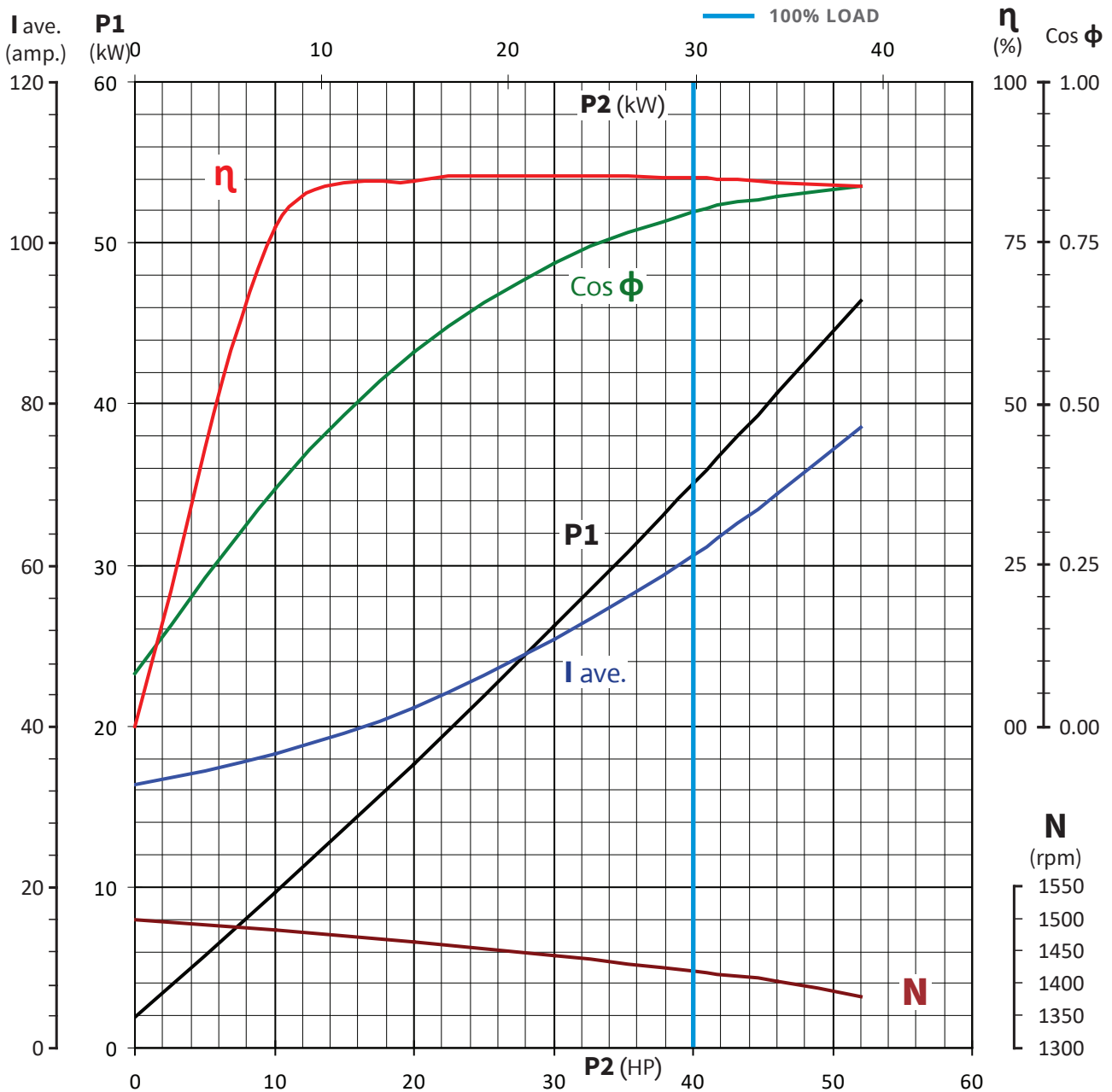



BOTTOM INTAKE MOTORS 10-INCH, 4-POLE, 50/60 Hz



Motor Performance Curves

Load	0%	25%	50%	75%	100%	115%	130%	Model	RX10BI-050-4
P2 (HP)	0.0	12.5	25.0	37.5	50.0	57.5	65.0	Motor Size (HP)	50
P2 (kW)	0.0	9.3	18.7	28.0	37.3	42.9	48.5	Motor Size (kW)	37
P1 (kW)	2.3	11.9	21.9	32.6	43.8	50.8	58.1	Voltage (V)	415
Current (Amp)	35.5	41.1	49.6	61.2	75.2	84.6	94.9	Frequency (Hz)	50
Efficiency (%)	0.0	78.5	85.1	85.7	85.1	84.4	83.5	Poles (Nos)	4
Cos phi (p.u)	0.091	0.402	0.615	0.742	0.811	0.836	0.852		
Speed (RPM)	1499	1483	1464	1444	1420	1403	1380		
Torque (Nm)	0.0	60.1	121.6	185.0	250.8	292.1	335.5		

Tolerances according to IEC 60034-1, Table-20.

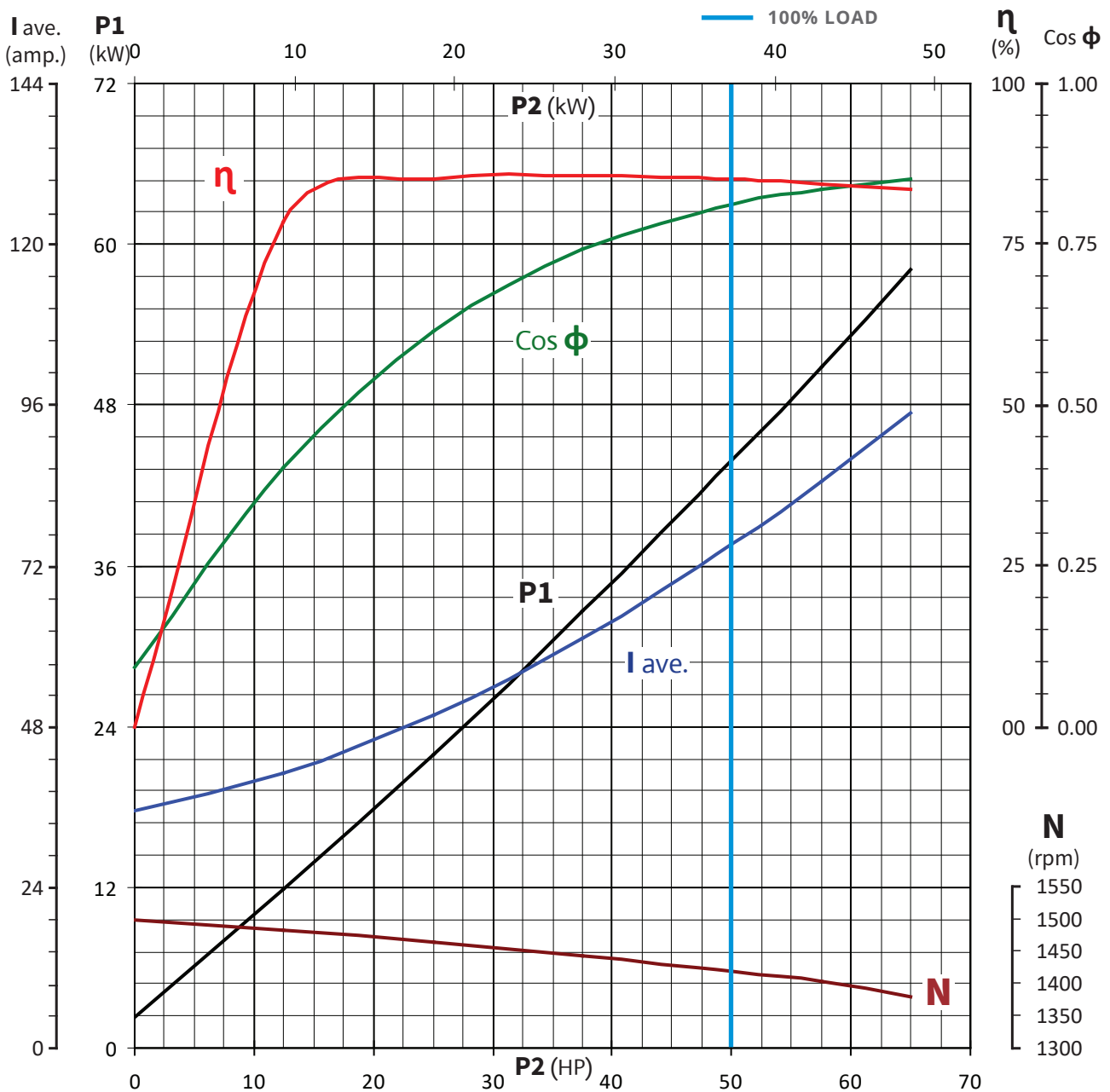

Motor Performance Curves

Load	0%	25%	50%	75%	100%	115%	130%	Model	RX10BI-060-4
P2 (HP)	0.0	15.0	30.0	45.0	60.0	69.0	78.0	Motor Size (HP)	60
P2 (kW)	0.0	11.2	22.4	33.6	44.8	51.5	58.2	Motor Size (kW)	45
P1 (kW)	2.6	14.1	26.1	38.9	52.3	61.0	70.4	Voltage (V)	415
Current (Amp)	40.5	48.7	59.2	73.1	89.9	101.7	114.9	Frequency (Hz)	50
Efficiency (%)	0.0	79.3	85.6	86.3	85.5	84.4	82.7	Poles (Nos)	4
Cos phi (p.u)	0.089	0.403	0.614	0.740	0.810	0.835	0.852		
Speed (RPM)	1499	1484	1466	1448	1425	1409	1388		
Torque (Nm)	0.0	72.0	145.7	221.4	299.9	348.9	400.4		

Tolerances according to IEC 60034-1, Table-20.

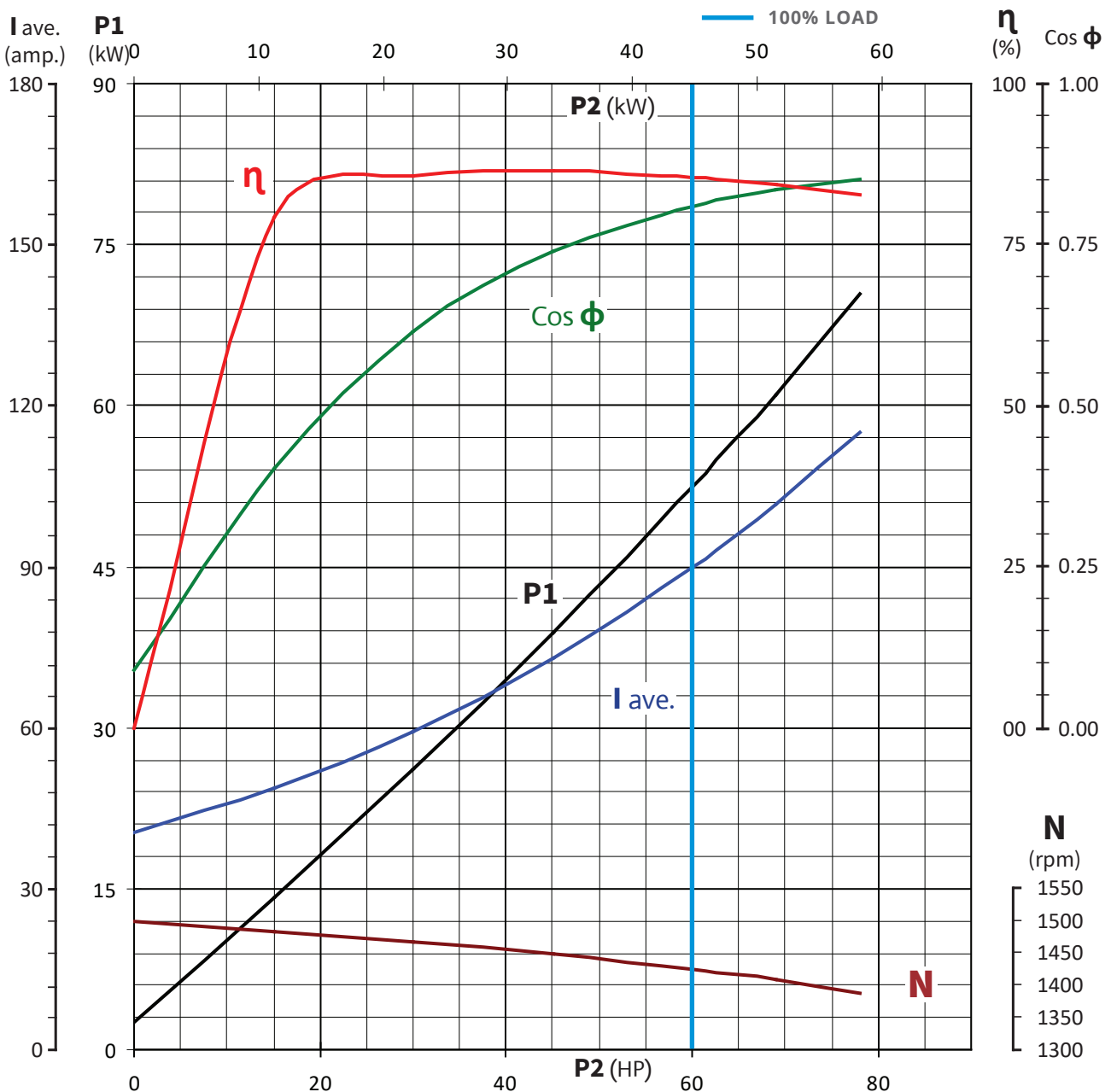



BOTTOM INTAKE MOTORS 10-INCH, 4-POLE, 50/60 Hz



Motor Performance Curves

Load	0%	25%	50%	75%	100%	115%	130%	Model	RX10BI-075-4
P2 (HP)	0.0	18.8	37.5	56.3	75.0	86.3	97.5	Motor Size (HP)	75
P2 (kW)	0.0	14.0	28.0	42.0	56.0	64.3	72.7	Motor Size (kW)	56
P1 (kW)	2.8	17.4	32.4	48.2	65.4	76.3	88.1	Voltage (V)	415
Current (Amp)	43.0	55.7	69.8	88.2	111.7	126.9	143.9	Frequency (Hz)	50
Efficiency (%)	0.0	80.5	86.3	87.1	85.6	84.4	82.6	Poles (Nos)	4
Cos phi (p.u)	0.089	0.434	0.646	0.760	0.814	0.836	0.851		
Speed (RPM)	1499	1483	1466	1447	1425	1408	1383		
Torque (Nm)	0.0	90.0	182.2	276.9	375.0	436.5	502.1		

Tolerances according to IEC 60034-1, Table-20.

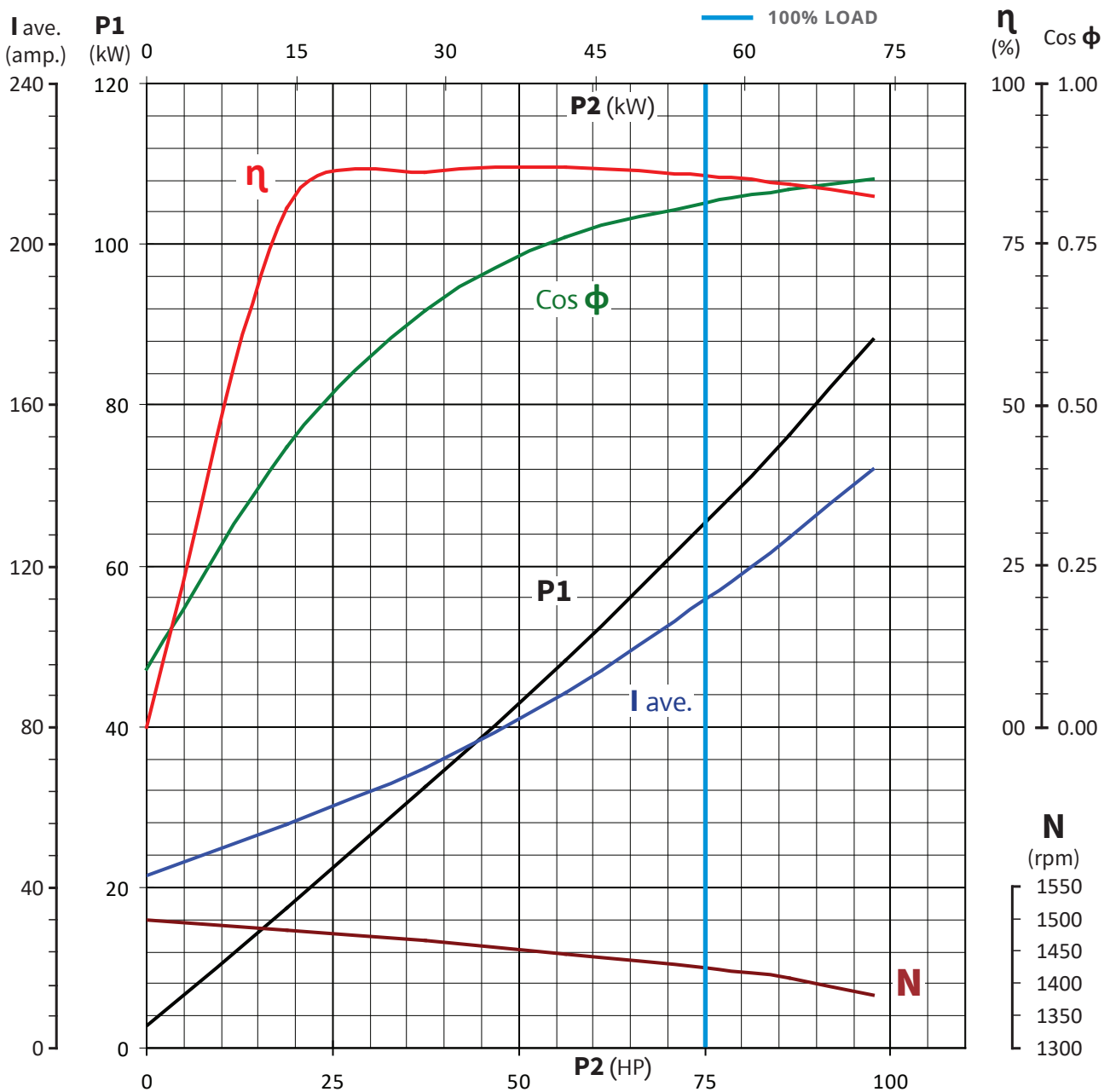

Motor Performance Curves

Load	0%	25%	50%	75%	100%	115%	130%	Model	RX10BI-100-4
P2 (HP)	0.0	25.0	50.0	75.0	100.0	115.0	130.0	Motor Size (HP)	100
P2 (kW)	0.0	18.7	37.3	56.0	74.6	85.8	97.0	Motor Size (kW)	75
P1 (kW)	3.1	22.3	42.3	64.2	87.2	103.3	122.1	Voltage (V)	415
Current (Amp)	68.4	77.2	95.0	120.6	151.0	174.7	203.5	Frequency (Hz)	50
Efficiency (%)	0.0	83.8	88.1	87.1	85.6	83.0	79.4	Poles (Nos)	4
Cos phi (p.u)	0.062	0.401	0.620	0.741	0.803	0.823	0.835		
Speed (RPM)	1499	1482	1463	1444	1420	1396	1368		
Torque (Nm)	0.0	120.2	243.4	370.0	501.6	586.8	676.8		

Tolerances according to IEC 60034-1, Table-20.

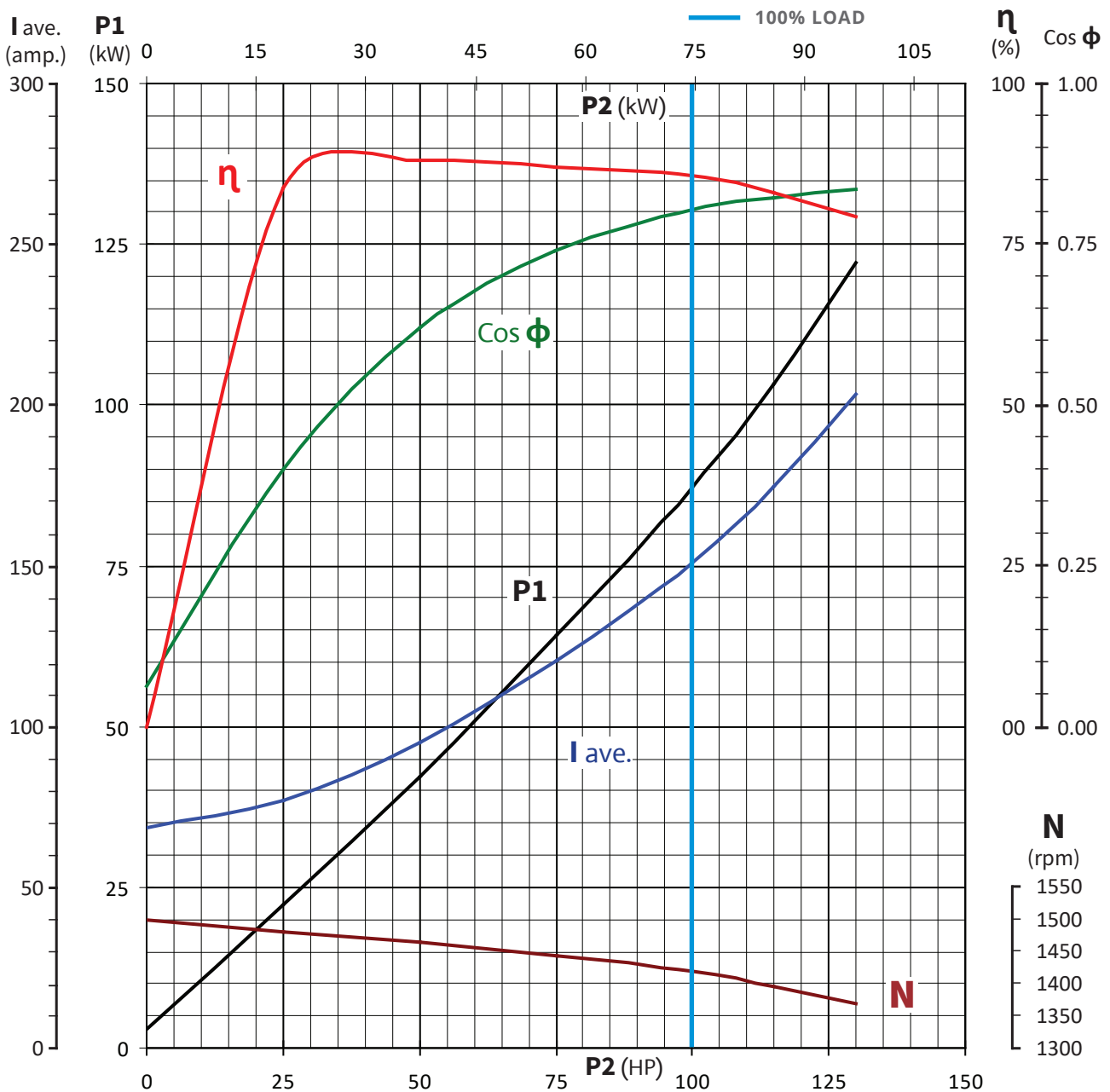



BOTTOM INTAKE MOTORS 10-INCH, 4-POLE, 50/60 Hz



Motor Performance Curves

Load	0%	25%	50%	75%	100%	115%	130%	Model	RX10BI-125-4
P2 (HP)	0.0	31.3	62.5	93.8	125.0	143.8	162.5	Motor Size (HP)	125
P2 (kW)	0.0	23.3	46.6	69.9	93.3	107.2	121.2	Motor Size (kW)	93
P1 (kW)	3.9	27.9	53.2	80.3	109.2	129.6	153.1	Voltage (V)	415
Current (Amp)	73.4	94.5	117.3	148.6	185.9	215.6	251.1	Frequency (Hz)	50
Efficiency (%)	0.0	83.5	87.7	87.1	85.4	82.8	79.2	Poles (Nos)	4
Cos phi (p.u)	0.073	0.411	0.631	0.752	0.817	0.836	0.848		
Speed (RPM)	1499	1483	1467	1448	1425	1403	1373		
Torque (Nm)	0.0	150.1	303.6	461.3	624.7	729.9	843.1		

Tolerances according to IEC 60034-1, Table-20.

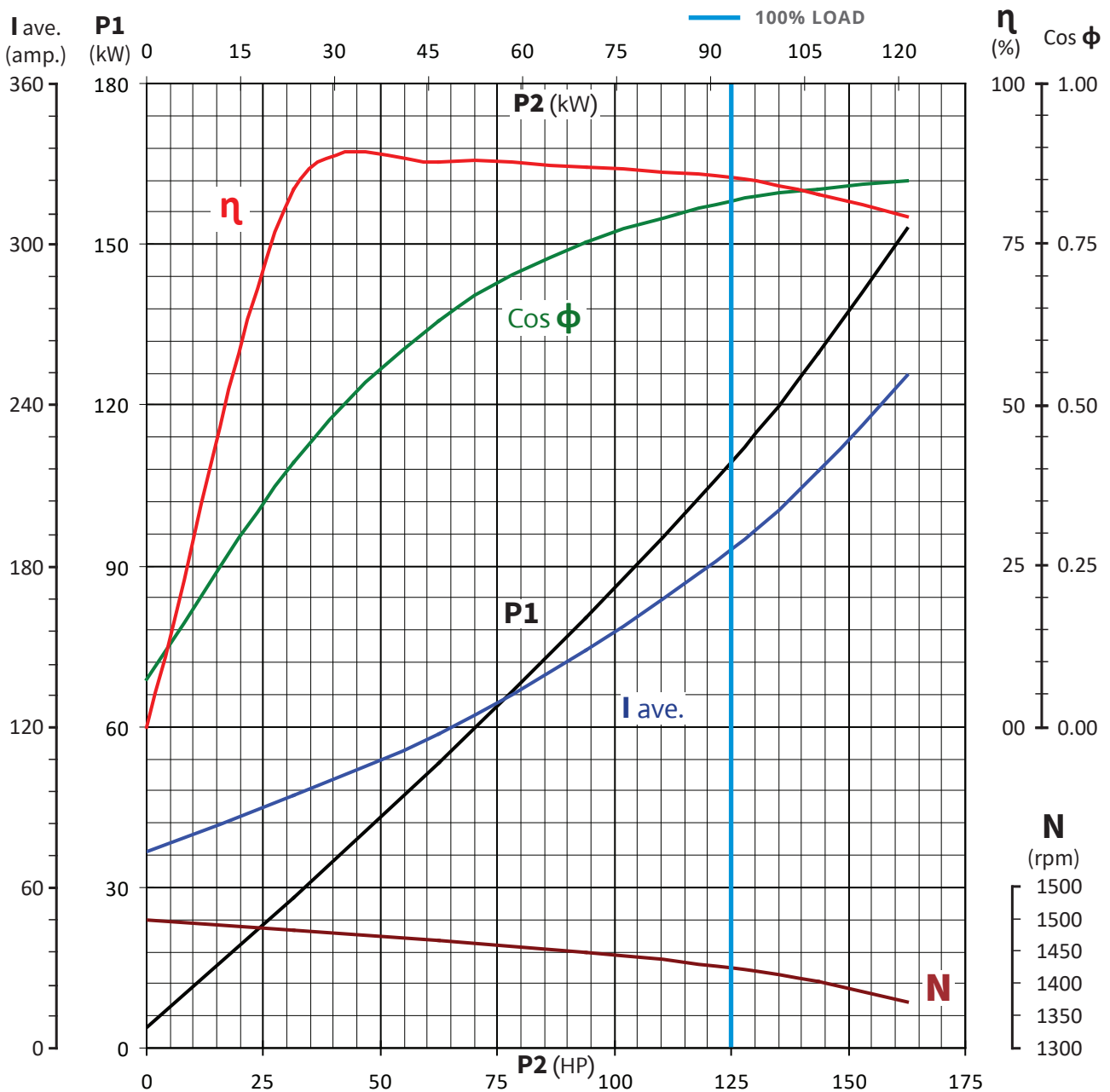

Motor Performance Curves

Load	0%	25%	50%	75%	100%	115%	130%	Model	RX10BI-150-4
P2 (HP)	0.0	37.5	75.0	112.5	150.0	172.5	195.0	Motor Size (HP)	150
P2 (kW)	0.0	28.0	56.0	83.9	111.9	128.7	145.5	Motor Size (kW)	112
P1 (kW)	5.8	34.8	64.7	96.0	130.3	154.5	182.3	Voltage (V)	415
Current (Amp)	93.5	114.7	140.3	176.5	222.1	256.4	297.4	Frequency (Hz)	50
Efficiency (%)	0.0	80.4	86.4	87.4	85.9	83.3	79.8	Poles (Nos)	4
Cos phi (p.u)	0.086	0.422	0.642	0.757	0.816	0.838	0.853		
Speed (RPM)	1499	1482	1464	1444	1420	1399	1372		
Torque (Nm)	0.0	180.3	364.9	554.9	752.4	878.1	1012.3		

Tolerances according to IEC 60034-1, Table-20.

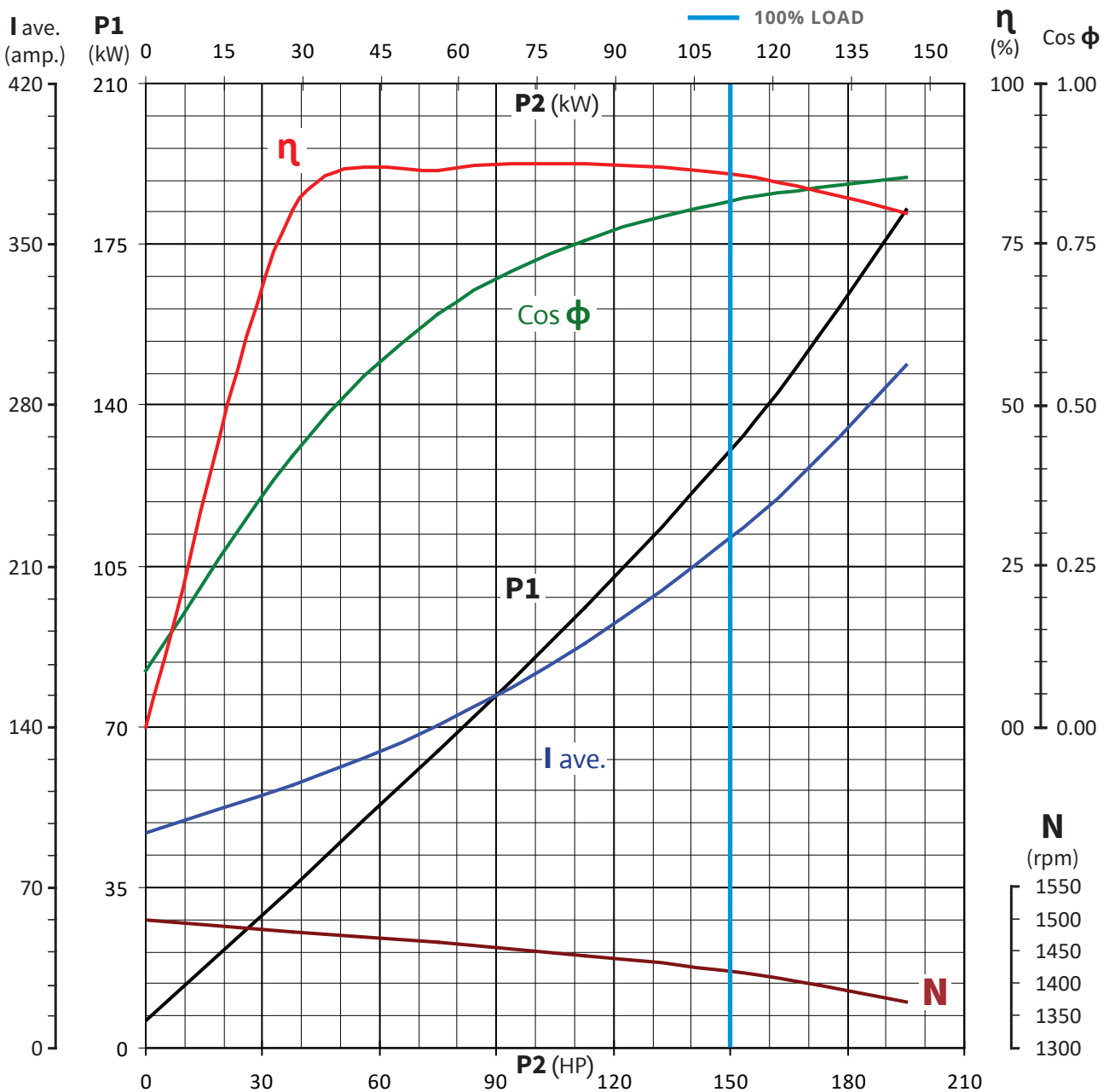



BOTTOM INTAKE MOTORS 10-INCH, 4-POLE, 50/60 Hz



Motor Performance Curves

Load	0%	25%	50%	75%	100%	115%	130%	Model	RX10BI-175-4
P2 (HP)	0.0	43.8	87.5	131.3	175.0	201.3	227.5	Motor Size (HP)	175
P2 (kW)	0.0	32.6	65.3	97.9	130.6	150.1	169.7	Motor Size (kW)	130
P1 (kW)	6.8	40.7	75.6	111.8	151.8	179.8	213.3	Voltage (V)	415
Current (Amp)	106.1	131.1	161.9	203.9	257.2	296.8	345.9	Frequency (Hz)	50
Efficiency (%)	0.0	80.2	86.3	87.5	86.0	83.5	79.6	Poles (Nos)	4
Cos phi (p.u)	0.089	0.432	0.650	0.763	0.821	0.843	0.858		
Speed (RPM)	1499	1481	1462	1441	1415	1393	1365		
Torque (Nm)	0.0	210.5	426.4	648.9	880.8	1029.0	1187.7		

Tolerances according to IEC 60034-1, Table-20.

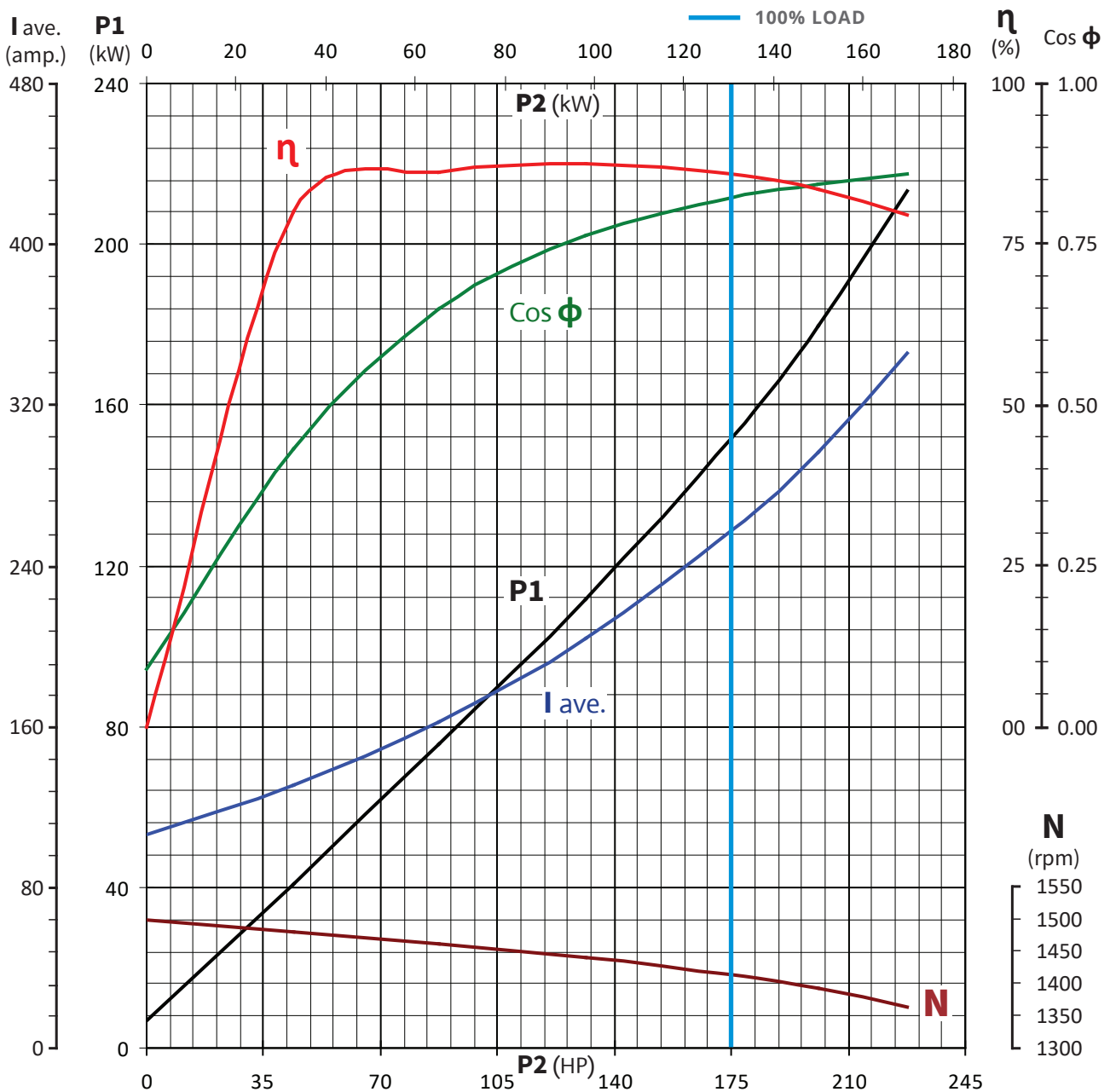

Motor Dimensions & Weight - 4 Pole - Three Phase

Motor Type	Motor Size		Thrust Load (Lbs)	L1 Motor Length (inch)	L Motor Length (inch)	Packing Dimension W x H x L (inch)	Weight (Lbs)	
	HP	KW					Without Packing	With Packing
DOL	RX10BI-040-4	40	30	18000	39.3	79.2		
	RX10BI-050-4	50	37	18000	42.4	82.4		
	RX10BI-060-4	60	45	18000	47.2	87.1		
	RX10BI-075-4	75	56	18000	51.1	91.0		
	RX10BI-100-4	100	75	18000	59.0	98.9		
	RX10BI-125-4	125	93	18000	66.9	106.8		
	RX10BI-150-4	150	112	18000	70.8	110.7		
	RX10BI-175-4	175	130	18000	74.7	114.6		
SD	RX10BI-040-4	40	30	18000	39.3	79.2		
	RX10BI-050-4	50	37	18000	42.4	82.4		
	RX10BI-060-4	60	45	18000	47.2	87.1		
	RX10BI-075-4	75	56	18000	51.1	91.0		
	RX10BI-100-4	100	75	18000	59.0	98.9		
	RX10BI-125-4	125	93	18000	66.9	106.8		
	RX10BI-150-4	150	112	18000	70.8	110.7		
	RX10BI-175-4	175	130	18000	74.7	114.6		

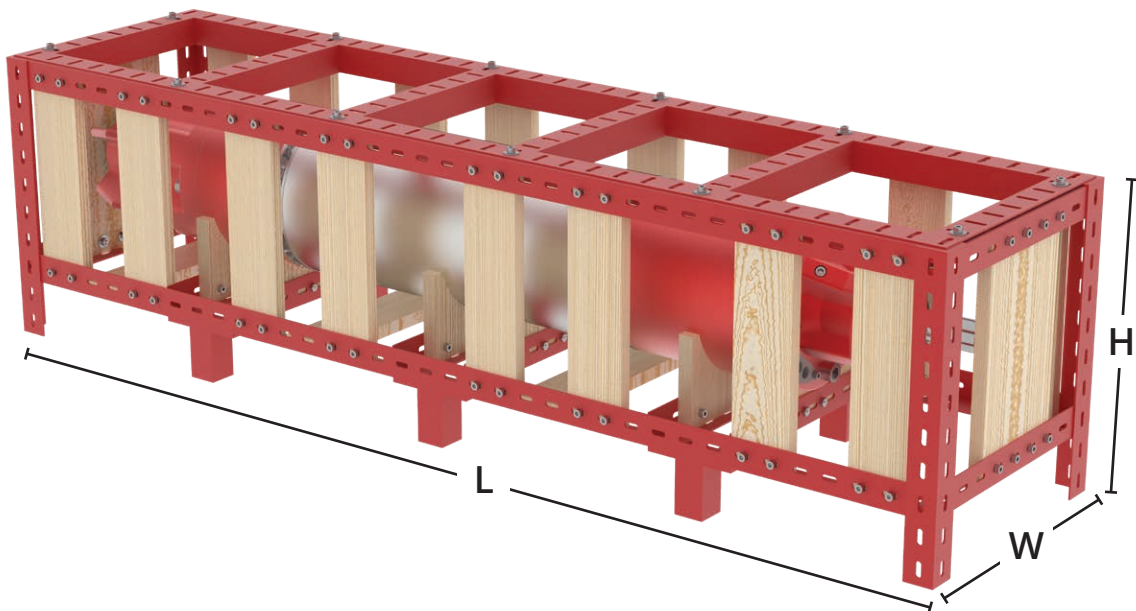

Motor Outline Drawing & Dimensions

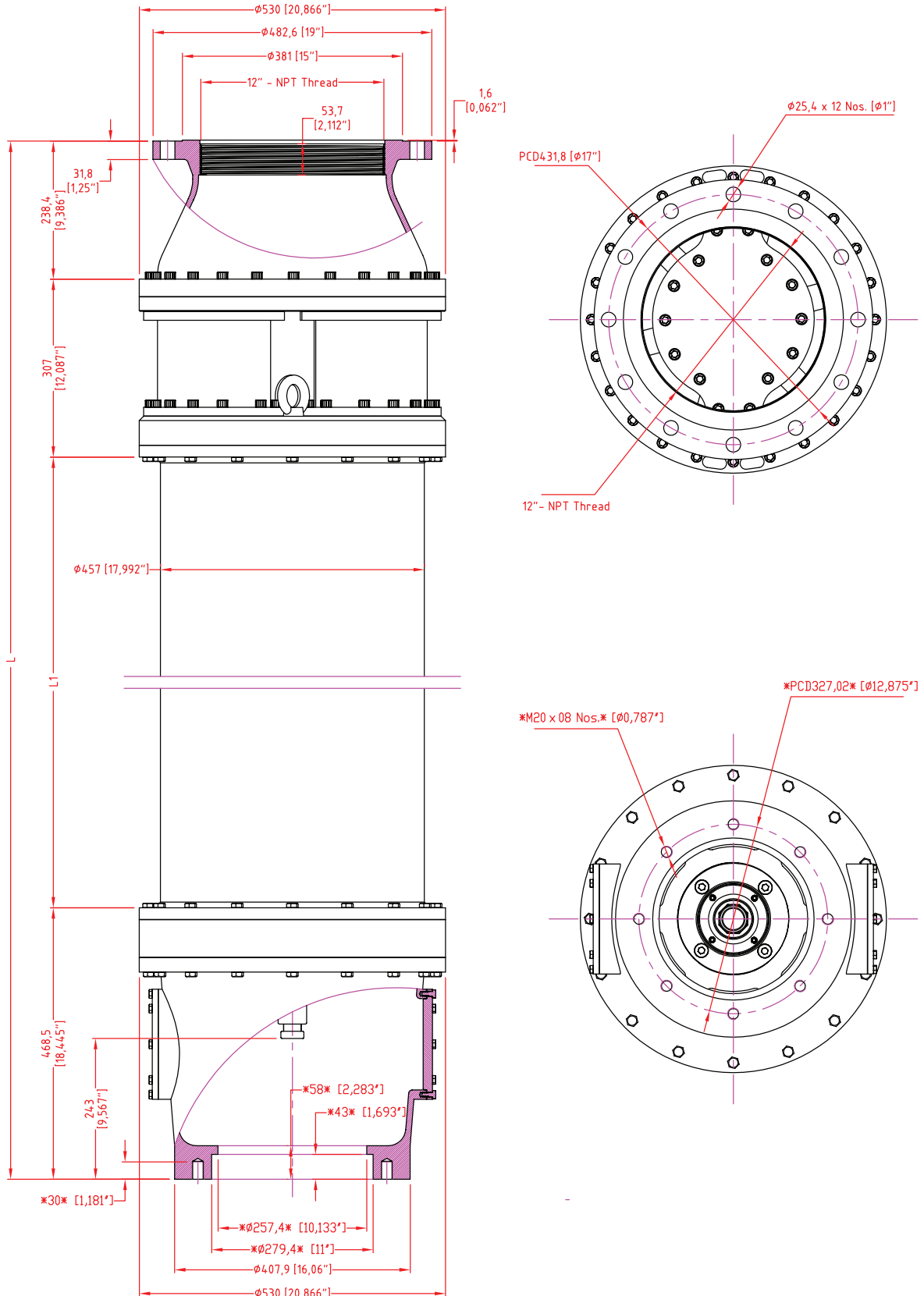

* The indicated dimensions can be machined as per clients requirements *

Exploded View

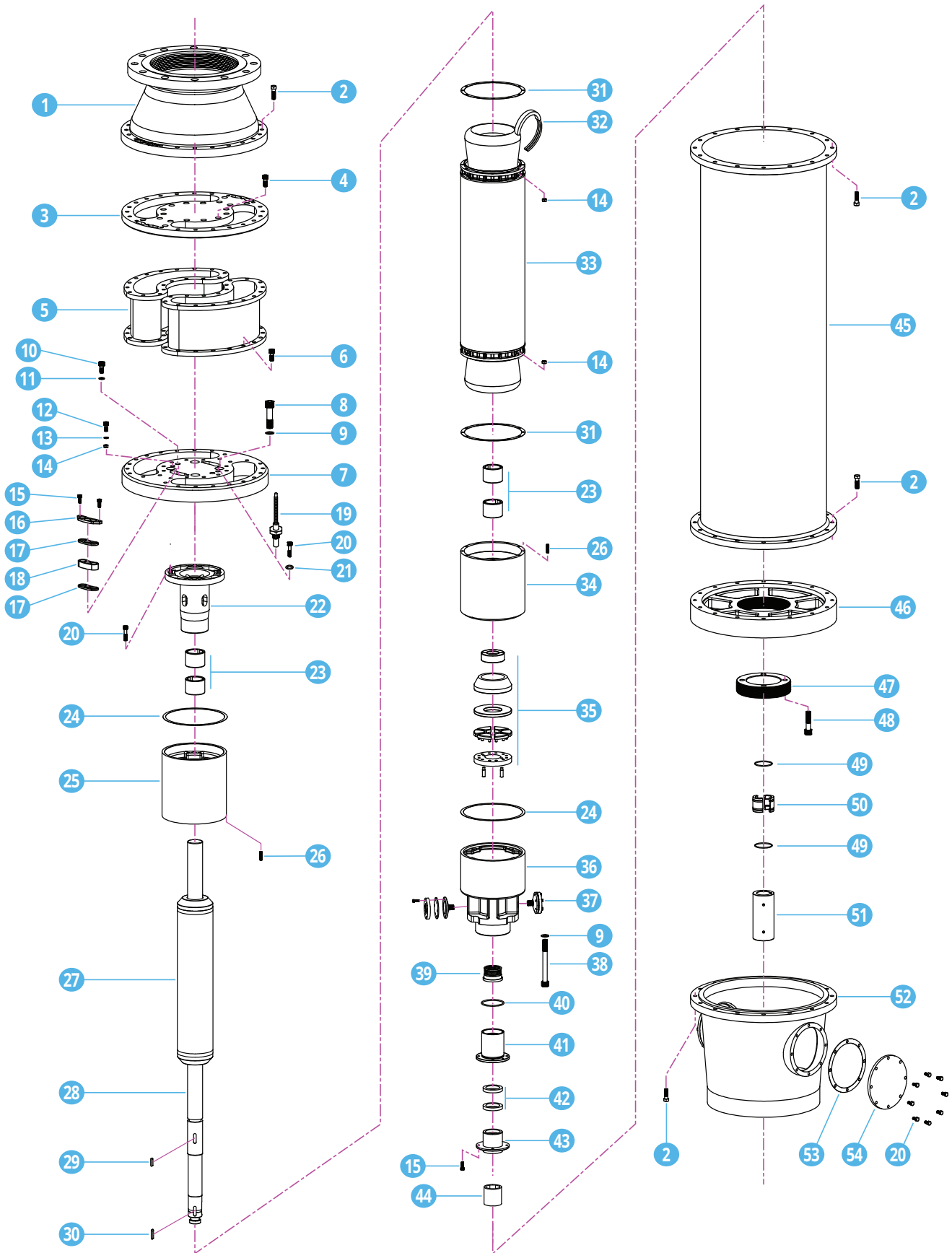



BOTTOM INTAKE MOTORS 10-INCH, 4-POLE, 50/60 Hz



Motor Parts List with Construction Material

Pos.	Item Code	Part Name	Material	Qty	Unit
1	60471200	Discharge Head	Cast Iron	1	Nr
2	60471078	Bolt Allen M10 x 35	Stainless Steel	56	Nr
3	60471225	Discharge Head Plate	Cast Iron	1	Nr
4	60471076	Bolt Allen M10 x 25	Stainless Steel	4	Nr
5	60471220	Top Manifold - BI10	Cast Iron	2	Nr
6	60471077	Bolt Allen M10 x 30	Stainless Steel		Nr
7	60471217	Top End Plate	Cast Iron	1	Nr
8	60161255	Bolt Allen M16 x 75	Stainless Steel	4	Nr
9	60161272	Washer Bonded / Dowty Seal M16	NBR / Carbon Steel	8	Nr
10	60101157	Bolt Allen M10 x 16	Stainless Steel	2	Nr
11	60101068	Washer Bonded / Dowty Seal M10	NBR / Stainless Steel	2	Nr
12	60161254	Bolt Allen M8 x 35	Stainless Steel	1	Nr
13	60161263	Spring Washer M8	Stainless Steel	1	Nr
14	60161255	Nut Hex M8	Stainless Steel	25	Nr
15	60161253	Bolt Allen M8 x 25	Stainless Steel	6	Nr
16	60161150	Cable Top Cover Plate	Carbon Steel	2	Nr
17	60271165	Washer Nylon (Motor Lead)	Nylon	2	Nr
18	60271180	Gasket Rubber (Motor Lead)	NBR	1	Nr
19	60101485	PT 100 Sensor	Stainless Steel	1	Nr
20	60161250	Bolt Allen M8 x 20	Stainless Steel	25	Nr
21	60161267	Washer Bonded / Dowty Seal M8	NBR / Carbon Steel	1	Nr
22	60161080	Upper Bearing Housing	Cast Iron	1	Nr
23	60271100	Carbon Bush	Carbon	4	Nr
24	60271150	Gasket Tesnit (Upper & Lower)	Tesnit	2	Nr
25	60271042	Upper Socket	Cast Iron	1	Nr
26	60271170	Set Screw / Stud Bolt M8 x 35	Stainless Steel	24	Nr
27	60271330	Rotor Lamination (Including Shaft + Copper Bars + End Ring)	Silicon Steel (50C800) + Stainless Steel + Copper	1	Set
28	602713XX	Rotor Shaft	Stainless Steel	1	Nr
29	60101145	Key for End Shaft	Stainless Steel	1	Nr
30	60471075	Key for Pump Coupling	Stainless Steel	1	Nr
31	60271152	Gasket Tesnit (Stator Flanges)	Tesnit	2	Nr
32A	601011XX	Motor Lead 1 x 16 / 25 / 35 / 70 mm2	PVC + Copper	48	Ft
32B	60101185	Motor Lead 1 x 10 mm2 (For Earthing)	PVC + Copper	16	Ft
33	602712XX	Stator Stack (Assembly) Including Sheet + Flanges	Silicon Steel (50C800) + Stainless Steel	1	Set
34	60271040	Lower Bearing Housing	Cast Iron	1	Nr
35	60271080	Thrust Bearing Complete - BI8	Stainless Steel / Carbon	1	Set
36	60471205	Thrust Support BI10- Suction piece	Cast Iron	1	Nr
37	60471265	Pressure Equalizing System		2	Set
38	60271142	Bolt Allen M16x180	Stainless Steel	4	Nr
39	6027109	Mechanical Seal Complete 10X10 WC	Silicon Tungsten Carbide (WC) + NBR + Stainless Steel	1	Nr
40	60271115	O-Ring Seal Support 75X3 10X10	NBR	1	Nr
41	60271075	Mech. Seal Bush Support 10X10	Cast Iron	1	Nr
42	60271085	Oil Seal 60x70x10	NBR	2	Nr
43	60271063	Seal Support Cover - Bronze 10 x 10	Bronze	1	Nr
44	60471250	Rubber Bush - BI10	NBR	1	Nr
45	60471255	Bottom Intake Jacket	Stainless Steel	1	Nr
46	60471215	Bottom End Plate	Cast Iron	1	Nr
47	60471270	Adjustment Flange	Stainless Steel	1	Nr
48	60101112	Bolt Allen M12x45	Stainless Steel	6	Nr
49	60471280	O-Ring Aligining Coupling	NBR	2	Nr
50	60471275	Aligining Coupling for Shaft BI10	Stainless Steel	1	Set
51	60471245	Pump Coupling BI10	Stainless Steel	1	Nr
52	60471207	Pump Adaptor	Cast Iron	1	Nr
53	60471262	Gasket Rubber (Adopter Coupler)	NBR	2	Nr
54	60471268	Plate (Adopter Coupler)	Stainless Steel	2	Nr

Cross Sectional View

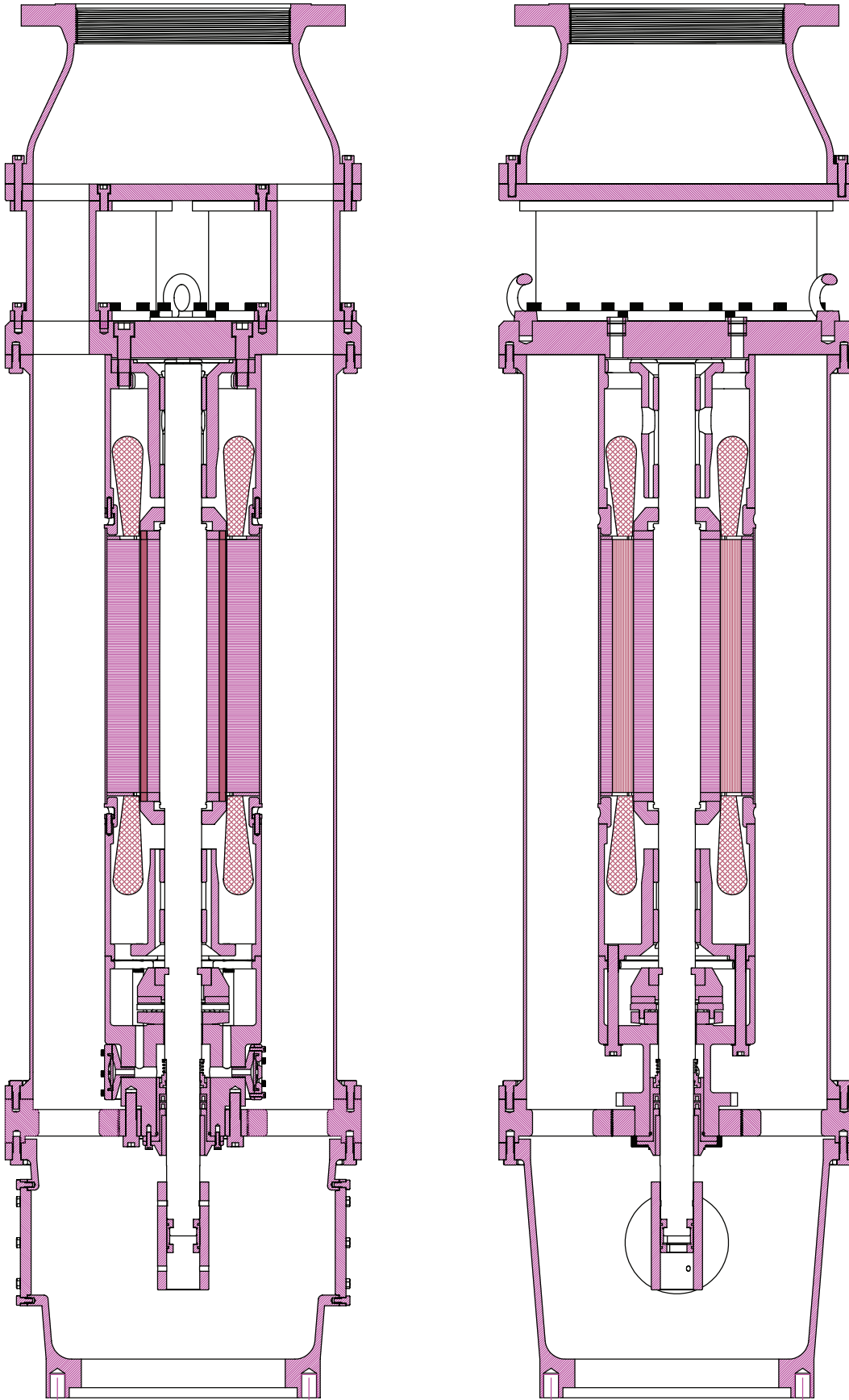

PT100 Temperature Sensor

PT100s, Platinum Resistance Transducers or RTDs (Resistance Temperature Detectors), present an economical and precise solution for temperature measurement due to the direct relationship between the resistance of the PT100 chip and the temperature being measured.

With Rotex motors the standard PT100s come in 3-wire configurations. As the number of wires increases, so does the accuracy of temperature measurement. This means that 3-wire units provide more precise temperature readings compared to 2-wire units. When utilized alongside an appropriate measuring instrument, PT100s accurately indicate the exact temperature of the sensor, regardless of its placement, with only a slight tolerance for accuracy deviation.

Key Specifications:

Temperature Range: PT100: -50 °C to +200 °C.

Accuracy Class: Class B

Nominal Resistance: 100 Ohms at 0 °C (The resistance changes by 0.3851 ohms for every 1 °C shift in temperature, with a Class B Device tolerance of +/- 0.0012 ohms).

Standard Sheath Material: Ceramic with SS304 Cover Tube

Wire Temperature Rating: 250 °C

Recommended Operating Current: 1 milliampere

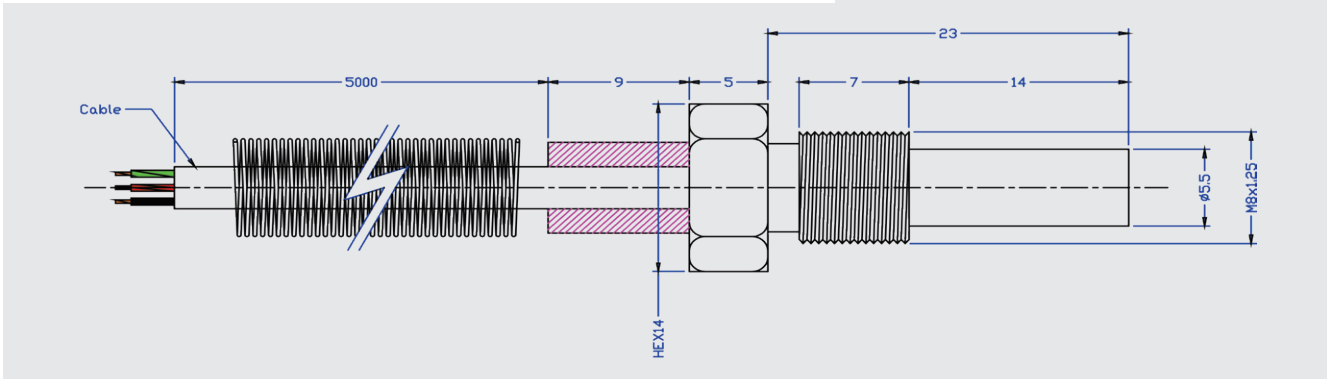
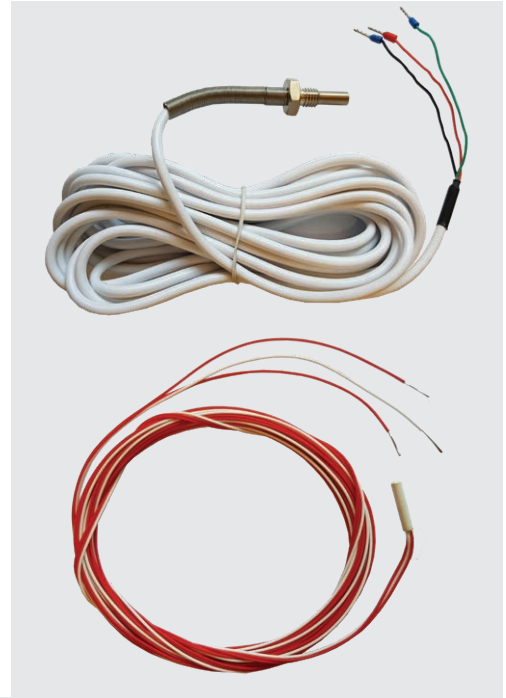

PT100 Temperature Sensor

Multiwire submersible cable specially made for borehole submersible motor's temperature sensors.

Available Packing: 328 or 1640 feet coil.

Cable Insulation: PE

Cable Sheath: Standard Grey High Temp PVC (Other materials and colours are available upon request)

Screen: Overall Aluminum/Polyester Laminate.

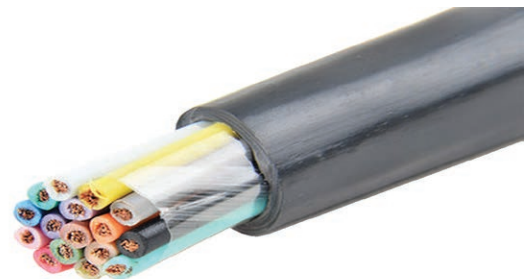

Nearest AWG	No. of Cores	Conductors Nos./Dia (mm)	Insulation Thickness (mm)	Nominal Wire to Wire Capacitance (pf/m)	Nominal Dia (mm)
24	3	7/0.20 TC	0.3	80	4.7
24	6	7/0.20 TC	0.3	80	5.5
24	12	7/0.20 TC	0.3	80	7.5



BOTTOM INTAKE MOTORS
10-INCH, 4-POLE, 50/60 Hz



Blank lined area for technical drawing or specifications.

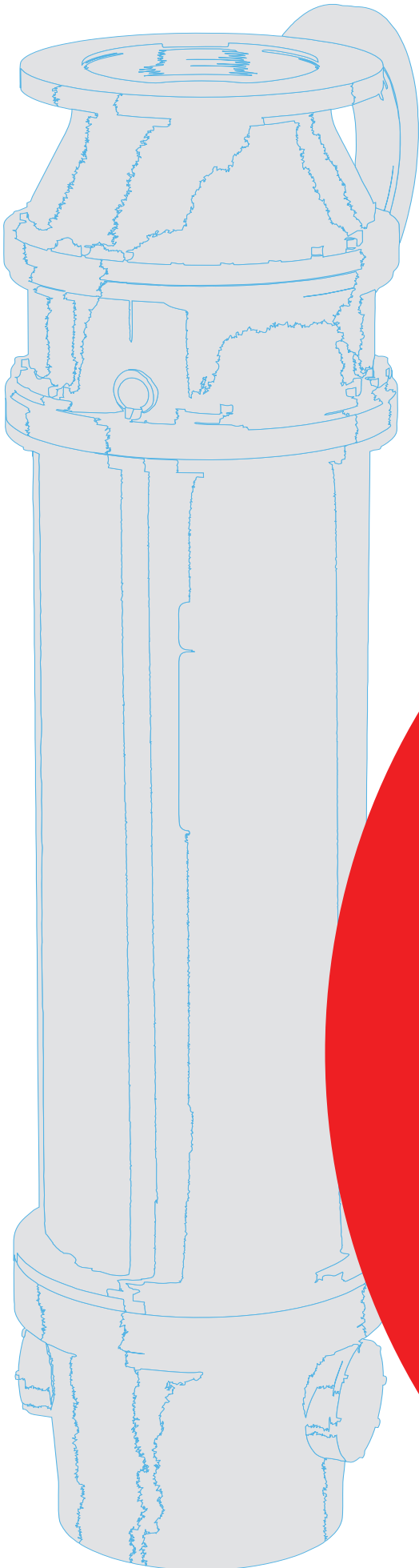

**ROTEX USA INC.
PRODUCT RANGE**

FOR 6-INCH BOREHOLE > RX6

230/380/460V - 60 Hz, 415V - 50 Hz

2 Poles, 3600 RPM / 2900 RPM

From: 5.5 HP (56 kW) To: 60 HP (45 kW)

FOR 8-INCH BOREHOLE > RX8

460V - 60 Hz, 415V - 50 Hz

2 Poles, 3600 RPM / 2900 RPM

From: 30 HP (56 kW) To: 175 HP (130 kW)

4 Poles, 1450 RPM / 1800 RPM

From: 7.5 HP (5.5 kW) To: 75 HP (56 kW)

FOR 10-INCH BOREHOLE > RX10

460V - 60 Hz, 415V - 50 Hz

2 Poles, 3600 RPM / 2900 RPM

From: 75 HP (56 kW) To: 270 HP (200 kW)

4 Poles, 1450 RPM / 1800 RPM

From: 40 HP (30 kW) To: 175 HP (130 kW)

FOR 12-INCH BOREHOLE > RX12

460V - 60 Hz, 415V - 50 Hz

2 Poles, 3600 RPM / 2900 RPM

From: 200 HP (150 kW) To: 400 HP (300 kW)

4 Poles, 1450 RPM / 1800 RPM

From: 100 HP (75 kW) To: 250 HP (186 kW)

**BOTTOM INTAKE > SUBMERSIBLE
MOTORS RX8-BI & RX10-BI**

230/460/575V - 60 Hz, 415V - 50 Hz

4 Poles, 1800 RPM / 1450 RPM

From: 7.5 HP (5.5 kW) To: 175 HP (130 kW)

2 Poles, 3600 RPM / 2900 RPM

From: 30 HP (22 kW) To: 270 HP (200 kW)

EFFLUENT PUMP > RX Series

½ Solid Handling - 115V - 60 Hz

From: 0.33 HP (0.25 kW) To: 0.5 HP (0.37 kW)

MOTOR CONTROL PANEL > RX CP

460V - 60 Hz, 415V - 50 Hz

From: 5.5 HP (56 kW) To: 70 HP (52 kW)



ROTEX USA INC.

23507 OLD Howth Road Hempstead,
TX 77445, United State of America

Tel: +1 (346) 368-4811

Email: info@rotexusa.com

Website: www.rotexusa.com

